



A7681(A7665)E/SA/JP/NA_ A7682E_A7683E_A7663E_S IM800C Compatible Design

LTE/GSM Module

SIMCom Wireless Solutions Limited

SIMCom Headquarters Building, Building 3, No. 289 Linhong
Road, Changning District, Shanghai P.R.China

Tel: 86-21-31575100

support@simcom.com

www.simcom.com

Document Title	A7681(A7665)E/SA/JP/NA_A7682E_A7683E_A7663E_SIM800C-Compatible Design
Version	1.01
Date	2026-06-02
Status	Released

GENERAL NOTES

SIMCOM OFFERS THIS INFORMATION AS A SERVICE TO ITS CUSTOMERS, TO SUPPORT APPLICATION AND ENGINEERING EFFORTS THAT USE THE PRODUCTS DESIGNED BY SIMCOM. THE INFORMATION PROVIDED IS BASED UPON REQUIREMENTS SPECIFICALLY PROVIDED TO SIMCOM BY THE CUSTOMERS. SIMCOM HAS NOT UNDERTAKEN ANY INDEPENDENT SEARCH FOR ADDITIONAL RELEVANT INFORMATION, INCLUDING ANY INFORMATION THAT MAY BE IN THE CUSTOMER'S POSSESSION. FURTHERMORE, SYSTEM VALIDATION OF THIS PRODUCT DESIGNED BY SIMCOM WITHIN A LARGER ELECTRONIC SYSTEM REMAINS THE RESPONSIBILITY OF THE CUSTOMER OR THE CUSTOMER'S SYSTEM INTEGRATOR. ALL SPECIFICATIONS SUPPLIED HEREIN ARE SUBJECT TO CHANGE.

COPYRIGHT

THIS DOCUMENT CONTAINS PROPRIETARY TECHNICAL INFORMATION WHICH IS THE PROPERTY OF SIMCOM WIRELESS SOLUTIONS LIMITED. COPYING, TO OTHERS AND USING THIS DOCUMENT, ARE FORBIDDEN WITHOUT EXPRESS AUTHORITY BY SIMCOM. OFFENDERS ARE LIABLE TO THE PAYMENT OF INDEMNIFICATIONS. ALL RIGHTS RESERVED BY SIMCOM IN THE PROPRIETARY TECHNICAL INFORMATION, INCLUDING BUT NOT LIMITED TO REGISTRATION GRANTING OF A PATENT, A UTILITY MODEL OR DESIGN. ALL SPECIFICATION SUPPLIED HEREIN ARE SUBJECT TO CHANGE WITHOUT NOTICE AT ANY TIME.

SIMCom Wireless Solutions Limited

SIMCom Headquarters Building, Building 3, No. 289 Linhong Road, Changning District, Shanghai P.R.China

Tel: +86 21 31575100

Email: simcom@simcom.com

For more information, please visit:

https://www.simcom.com/technical_files.html

For technical support, or to report documentation errors, please visit:

https://www.simcom.com/online_questions.html or email to: support@simcom.com

Copyright © 2025 SIMCom Wireless Solutions Limited All Rights Reserved.

Version History

Date	Version	Description of change	Author
2025-11-17	1.00	Original	Fangwei.Wen
2026-06-02	1.01	Add A7665SA、A7665NA、A7681JP	Xu.Li

SIMCom
Confidential

Contents

1 Introduction	7
1.1 Module Overview	7
1.2 Features Overview	8
2 Package Introduction	11
2.1 Pin Assignment Overview	11
2.2 PIN definition	12
2.3 Top and Bottom View	17
2.4 Recommended PCB footprint outline	18
2.5 Recommended SMT Stencil	19
2.6 PIN Size Comparison	22
3 Hardware Reference Design	25
3.1 Power Supply	25
3.1.1 A7681E	26
3.1.2 A7682E	26
3.1.3 A7683E/A7663E	26
3.1.4 SIM800C	27
3.2 Power on/off and Circuit	27
3.3 Reset Circuit	29
3.4 USB Interface	31
3.5 UART Interface	32
3.6 USIM Interface	35
3.7 SD/MMC Interface	36
3.8 Audio Interface	37
3.9 Network/STATUS Indication	39
3.10 ADC Interface	39
3.11 GNSS Interface	40
3.12 RF Interface	40
3.12.1 Passive Antenna for LTE/GNSS	40
3.12.2 Active Antenna for GNSS	41
3.12.3 Bluetooth Antenna Interface	42
4 Appendix	43
4.1 Related documents	43
4.2 Terms and Abbreviation	43

Table Index

Table 1: Module basic information comparison	7
Table 2: Module function comparison	8
Table 3: Pin type definition	12
Table 4: Module pin definition comparison	13
Table 5: Module recommended supply voltage comparison	25
Table 6: TVS for USB part number list	32
Table 7: Recommended TVS Diodes for VBUS	32
Table 8: TVS for USIM socket part number list	36
Table 9: ADC interface parameters	39
Table 10: Recommended TVS	41
Table 11: Related documents	43
Table 12: Terms and Abbreviation	43

SIMCom
Confidential

Figure Index

Figure 1:A7681E/A7682E/A7683E/A7663E/SIM800C pin assignment (Top view)	11
Figure 2:A7681E/A7682E/A7683E/A7663E/SIM800C top and bottom view	17
Figure 3: Recommended PCB footprint outline (Unit: mm)	18
Figure 4: Recommended SMT stencil of A7681E and A7683E (Unit: mm)	19
Figure 5: Recommended SMT stencil of A7682E and A7663E (Unit: mm)	20
Figure 6: Recommended SMT stencil of SIM800C (Unit: mm)	21
Figure 7: Comparison of PIN Size of A7681E	22
Figure 8: Comparison of PIN Size of A7683E	23
Figure 9: Comparison of PIN Size of A7663E	23
Figure 10: Comparison of PIN Size of A7682E and SIM800C	24
Figure 11: Power supply application circuit	25
Figure 12: Burst current cause VBAT drop	26
Figure 13: Burst transmission power requirements (SIM800C)	27
Figure 14: Power on/off reference circuit	28
Figure 15:A7681E/A7682E/A7683E/A7663E Reset reference circuit	29
Figure 16: SIM800C PIN 28 reference circuits (RTC supply from capacitor)	30
Figure 17: SIM800C PIN 28 reference circuits (non-chargeable battery)	30
Figure 18: SIM800C PIN 28 reference circuits (rechargeable battery)	30
Figure 19: USB reference circuit	31
Figure 20: UART Full modem	33
Figure 21: UART Null modem	33
Figure 22: Triode level conversion circuit	34
Figure 23: Triode level conversion circuit	34
Figure 24: SIM interface reference circuit (6PIN)	35
Figure 25: SIM interface reference circuit (8PIN)	36
Figure 26: SD/MMC interface recommendation circuit for A7683E/A7663E	37
Figure 27: Analog audio recommendation circuit for A7683E/A7663E/SIM800C	37
Figure 28: Analog audio recommendation circuit for A7682E	38
Figure 29: Analog audio recommendation circuit for A7681E	38
Figure 30: NETLIGHT/STATUS reference circuit	39
Figure 31: Antenna matching circuit	40
Figure 32: Antenna matching circuit	41
Figure 33: Bluetooth antenna matching circuit	42





1 Introduction

This document describes the differences between A7681(A7665)E/SA/JP/NA, A7682E, A7683E, A7663E and SIM800C, Customers can quickly design and develop applications using A7681E, A7682E, A7683E, A7663E and SIM800C modules.

1.1 Module Overview

A7682E module supports GSM / LTE CAT1; A7681E, A7683E and A7663E module only supports LTE CAT1; SIM800C module supports GSM / GPRS; Customers can choose different types of modules according to their needs to meet diversified market demands.

Table 1: Module basic information comparison

Modules	Renderings	Package	Size	Description
A7681E		85 LGA pins	15.7*17.6*2.1mm	LTE CAT-1
A7665SA		85 LGA pins	15.7*17.6*2.1mm	LTE CAT-1
A7665E		85 LGA pins	15.7*17.6*2.1mm	LTE CAT-1
A7665NA		85 LGA pins	15.7*17.6*2.1mm	LTE CAT-1

A7681JP		85 LGA pins	15.7*17.6*2.1mm	LTE CAT-1
A7682E		85 LGA pins	19.6*19.6*2.4 mm	LTE CAT-1 and GSM
A7683E		85 LGA pins	15.7*17.6*2.4mm	LTE CAT-1
A7663E		85 LGA pins	19.6*19.6*2.4	LTE CAT-1
SIM800C		42 LCC pins	15.7*17.6*2.3mm	GSM

Confidential

1.2 Features Overview

This chapter lists the function parameters of A7681 (A7665) E/SA/JP/NA, A7682E, A7683E, A7663E and SIM800C, The comparison is as follows:

Table 2: Module function comparison

Function	A7681 (A7665) E/SA/JP/NA	A7682E	A7683E	A7663E	SIM800C
Power	Power supply range: 3.3V~4.2V Typical value: 3.8V	Power supply range: 3.4V~4.2V Typical value: 3.8V	Power supply range: 3.4V~4.2V Typical value: 3.8V	Power supply range: 3.4V~4.2V Typical value: 3.8V	Power supply range: 3.4V~4.4V Typical value: 4.0V
Peak current	1A	2A	700mA	700mA	2A
Sleep current	<2mA (AT+CFUN=0)	<2mA (AT+CFUN=0)	<2mA (AT+CFUN=0)	<2mA (AT+CFUN=0)	0.6mA (AT+CFUN=0)
Frequency band	LTE:1/3/5/7/8/20/28	EGSM900/DCS1800 LTE:1/3/5/7/8/20	LTE:1/3/5/7/8/20/28	LTE:1/3/5/7/8/20/28	GSM850/EGSM900/DCS 1800/PCS1900
GNSS	GPS/GLONASS/BeiDou	NA	NA	GPS/GLONASS/BeiDou	NA
Bluetooth	NA	NA	NA	NA	Need software support
Temperature range	Operation temperature: -30°C ~ +75°C Extended operation temperature: -40°C ~ +85°C* Storage temperature: -45°C ~ +90°C	Operation temperature: -30°C ~ +80°C Extended operation temperature: -40°C ~ +85°C*	Operation temperature: -30°C ~ +75°C Extended operation temperature: -40°C ~ +85°C*	Operation temperature: -30°C ~ +75°C Extended operation temperature: -40°C ~ +85°C*	Operation temperature: -40°C ~ +85°C Storage temperature: -45°C ~ +90°C

UART interface	<ul style="list-style-type: none"> ● Main serial port Baud rate support from 300bps to 3.6Mbps AT command and data can be sent through the serial port Support RTS/CTS Hardware flow control ● UART3 One ordinary two-wire serial port The default baud rate is 115200bps. ● Debug serial port Supports debug usage 	<ul style="list-style-type: none"> ● Main serial port Baud rate support from 300bps to 3.6Mbps AT command and data can be sent through the serial port Support RTS/CTS Hardware flow control ● UART3 One ordinary two-wire serial port The default baud rate is 115200bps. ● Debug serial port Supports debug usage 	<ul style="list-style-type: none"> ● Main serial port Baud rate support from 300bps to 3.6Mbps AT command and data can be sent through the serial port Support RTS/CTS Hardware flow control ● UART3 One ordinary two-wire serial port The default baud rate is 115200bps. ● Debug serial port Supports debug usage 	<ul style="list-style-type: none"> ● Main serial port Baud rate support from 300bps to 3.6Mbps AT command and data can be sent through the serial port Support RTS/CTS Hardware flow control ● UART3 One ordinary two-wire serial port The default baud rate is 115200bps. ● Debug serial port Supports debug usage 	<p>Serial port:</p> <ul style="list-style-type: none"> ● Default one Full modem serial port ● It can be used for AT commands or data stream ● Support RTS/CTS hardware handshake and software ON/OFF flow control ● Multiplex ability according to GSM 07.10 Multiplexer Protocol ● Adaptive baud rate support from 1200 bps to 115200bps ● Upgrading firmware
USIM Card interface	Support 1.8V/3V USIM card	Support 1.8V/3V USIM card	Support 1.8V/3V USIM card	Support 1.8V/3V USIM card	Support 1.8V/3V USIM card
Audio feature	MAX:37mW(32Ω)	MAX:37mW(32Ω)	MAX:37mW(32Ω)	MAX:37mW(32Ω)	MAX:90mW(32Ω)
PCM interface	NA	NA	NA	NA	NA
SPI interface	NA	NA	NA	NA	NA
USB interface	USB 2.0 compliant, host mode not supported. This interface supports AT command sending, data transmission,	USB 2.0 compliant, host mode not supported. This interface supports AT command sending, data transmission,	USB 2.0 compliant, host mode not supported. This interface supports AT command sending, data transmission,	USB 2.0 compliant, host mode not supported. This interface supports AT command sending, data transmission,	USB 2.0 compliant, host mode not supported. It can be used for debugging and upgrading firmware

	software debugging and upgrading.	software debugging and upgrading.	software debugging and upgrading.	software debugging and upgrading.	
SD Card interface	NA	NA	SD interface	SD interface	NA
ADC interface	<ul style="list-style-type: none"> ● Provide an analog-to-digital conversion interface ● Voltage range: 0~1.2V ● Resolution:12 bits 	<ul style="list-style-type: none"> ● Provide an analog-to-digital conversion interface ● Voltage range: 0~1.8V ● Resolution: 9 bits 	<ul style="list-style-type: none"> ● Provide an analog-to-digital conversion interface ● Voltage range:0~1.2V ● Resolution:12 bits 	<ul style="list-style-type: none"> ● Provide an analog-to-digital conversion interface ● Voltage range: 0~1.2V ● Resolution:12 bits 	<ul style="list-style-type: none"> ● Provide an analog-to-digital conversion interface ● Voltage range: 0~2.8V ● Resolution:10 bits
Network indication	NETLIGHT: Network indication	NETLIGHT: Network indication	NETLIGHT: Network indication	NETLIGHT: Network indication	NETLIGHT: Network indication
Antenna interface	Main antenna: ANT_MAIN GNSS antenna: ANT_GNSS	Main antenna: RF_ANT	Main antenna: RF_ANT	Main antenna: ANT_MAIN GNSS antenna: ANT_GNSS	Main antenna: RF_ANT Bluetooth antenna: BT_ANT
Software upgrade	Upgrade software via USB	Upgrade software via USB	Upgrade software via USB	Upgrade software via USB	Upgrade software via USB or UART

NOTE

In the extended operating temperature range, the module can work normally, but cannot guarantee full compliance with 3GPP test specifications.

2 Package Introduction

2.1 Pin Assignment Overview

The following figure shows the pin assignment of A7681(A7665)E/SA/JP/NA, A7682E, A7683E and SIM800C.

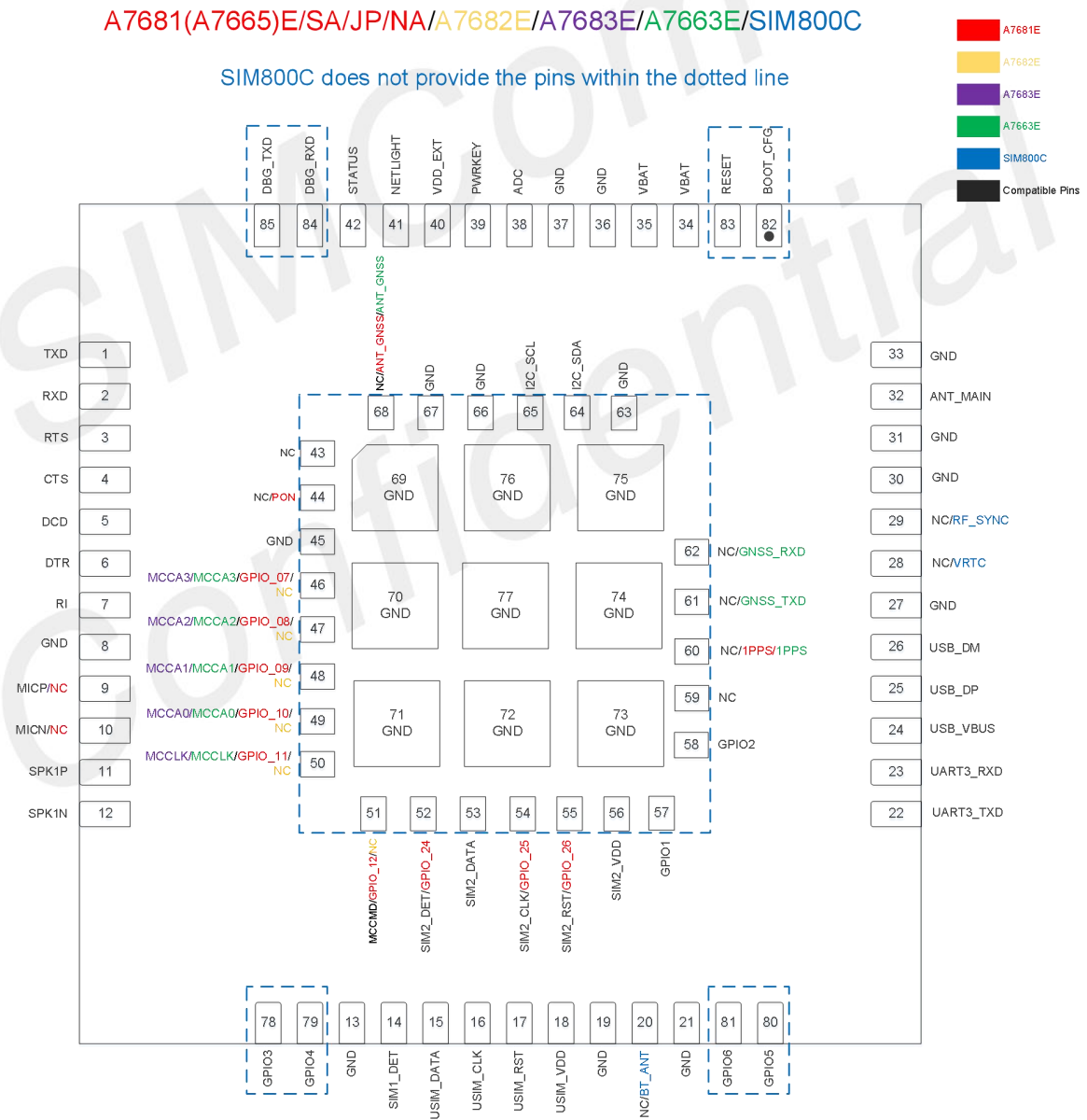

Figure 1:A7681(A7665)E/SA/JP/NA、A7682E/A7683E/A7663E/SIM800C pin assignment (Top view)

NOTE

1. The black font indicates the compatible defined pins.
2. The SIM800C module do not provide inner ring pins.
3. The A7681(A7665)E/SA/JP/NA, A7663E, A7682E and A7683E module have 8 more outer ring pins (78, 79, 80, 81, 82, 83, 84 and 85).
4. For more details information, please refer to each HD guide.

2.2 PIN definition

This chapter describes the pin definition and comparison of A7681(A7665)E/SA/JP/NA, A7682E, A7683E and SIM800C.

Table 3: Pin type definition

Abbreviation	Description
PI	Power Input
PO	Power Output
AI	Analog Input
AO	Analog Output
I/O	Input or Output
DI	Digital Input
DO	Digital Output
DOH	Default output high-level
DOL	Default output low-level
PU	pull up
PD	Pull down
OD	Open drain

Table 4: Module pin definition comparison

Pin No.	A7681 (A7665) E/SA/JP/NA		A7682E		A7683E		A7663E		SIM800C	
	Pin Name	Power domain	Pin Name	Power domain	Pin Name	Power domain	Pin Name	Power domain	Pin Name	Power domain
1	UART1_TXD	1.8V	UART1_TXD	1.8V	UART1_TXD	1.8V	UART1_TXD	1.8V	UART1_TXD	2.8V
2	UART1_RXD	1.8V	UART1_RXD	1.8V	UART1_RXD	1.8V	UART1_RXD	1.8V	UART1_RXD	2.8V
3	UART1_RTS	1.8V	UART1_RTS	1.8V	UART1_RTS	1.8V	UART1_RTS	1.8V	UART1_RTS	2.8V
4	UART1_CTS	1.8V	UART1_CTS	1.8V	UART1_CTS	1.8V	UART1_CTS	1.8V	UART1_CTS	2.8V
5	UART1_DCD	1.8V	UART1_DCD	1.8V	UART1_DCD	1.8V	UART1_DCD	1.8V	UART1_DCD	2.8V
6	UART1_DTR	1.8V	UART1_DTR	1.8V	UART1_DTR	1.8V	UART1_DTR	1.8V	UART1_DTR	2.8V
7	UART1_RI	1.8V	UART1_RI	1.8V	UART1_RI	1.8V	UART1_RI	1.8V	UART1_RI	2.8V
8	GND	-	GND	-	GND	-	GND	-	GND	-
9	NC	-	MICP	-	MICP	-	MICP	-	MICP	-
10	NC	-	MICN	-	MICN	-	MICN	-	MICN	-
11	SPK1P	-	SPK1P	-	SPK1P	-	SPK1P	-	SPKP	-
12	SPK1N	-	SPK1N	-	SPK1N	-	SPK1N	-	SPKN	-
13	GND	-	GND	-	GND	-	GND	-	GND	-
14	SIM1_DET	1.8V	SIM1_DET	1.8V	SIM1_DET	1.8V	SIM1_DET	1.8V	SIM_DET	2.8V
15	SIM1_DATA	1.8V/3.0V	SIM1_DATA	1.8V/3.0V	SIM1_DATA	1.8V/3.0V	SIM1_DATA	1.8V/3.0V	SIM_DATA	1.8V/3.0V
16	SIM1_CLK	1.8V/3.0V	SIM1_CLK	1.8V/3.0V	SIM1_CLK	1.8V/3.0V	SIM1_CLK	1.8V/3.0V	SIM_CLK	1.8V/3.0V
17	SIM1_RST	1.8V/3.0V	SIM1_RST	1.8V/3.0V	SIM1_RST	1.8V/3.0V	SIM1_RST	1.8V/3.0V	SIM_RST	1.8V/3.0V
18	SIM1_VDD	1.8V/3.0V	SIM1_VDD	1.8V/3.0V	SIM1_VDD	1.8V/3.0V	SIM1_VDD	1.8V/3.0V	SIM_VDD	1.8V/3.0V
19	GND	-	GND	-	GND	-	GND	-	GND	-
20	NC	-	NC	-	NC	-	NC	-	BT_ANT	-
21	GND	-	GND	-	GND	-	GND	-	GND	-

22	UART3_TXD	1.8V	UART3_TXD	1.8V	UART3_TXD	1.8V	UART3_TXD	1.8V	UART2_TXD	2.8V
23	UART3_RXD	1.8V	UART3_RXD	1.8V	UART3_RXD	1.8V	UART3_RXD	1.8V	UART2_RXD	2.8V
24	USB_VBUS	3.0~5.2V	USB_VBUS	3.0~5.2V	USB_VBUS	3.0~5.2V	USB_VBUS	3.0~5.2V	USB_VBUS	4.3~7.0V
25	USB_DP	-	USB_DP	-	USB_DP	-	USB_DP	-	USB_DP	-
26	USB_DM	-	USB_DM	-	USB_DM	-	USB_DM	-	USB_DN	-
27	GND	-	GND	-	GND	-	GND	-	GND	-
28	NC	-	NC	-	NC	-	NC	-	VRTC	1.2~3.0V
29	NC	-	NC	-	NC	-	NC	-	RF_SYNC	2.8V
30	GND	-	GND	-	GND	-	GND	-	GND	-
31	GND	-	GND	-	GND	-	GND	-	GND	-
32	ANT_MAIN	-	RF_ANT	-	RF_ANT	-	ANT_MAIN	-	GSM_ANT	-
33	GND	-	GND	-	GND	-	GND	-	GND	-
34	VBAT	3.3~4.2V	VBAT	3.4~4.2V	VBAT	3.4~4.2V	VBAT	3.4~4.2V	VBAT	3.4~4.4V
35	VBAT	3.3~4.2V	VBAT	3.4~4.2V	VBAT	3.4~4.2V	VBAT	3.4~4.2V	VBAT	3.4~4.4V
36	GND	-	GND	-	GND	-	GND	-	GND	-
37	GND	-	GND	-	GND	-	GND	-	GND	-
38	ADC	0-1.8V	ADC	0-1.8V	ADC	0-1.8V	ADC	0-1.8V	ADC	0-2.8V
39	PWRKEY	VBAT	PWRKEY	VBAT	PWRKEY	VBAT	PWRKEY	VBAT	PWRKEY	VBAT
40	VDD_EXT	1.8V	VDD_EXT	1.8V	VDD_EXT	1.8V	VDD_EXT	1.8V	VDD_EXT	2.8V
41	NETLIGHT	1.8V	NETLIGHT	1.8V	NETLIGHT	1.8V	NETLIGHT	1.8V	NETLIGHT	2.8V
42	STATUS	1.8V	STATUS	1.8V	STATUS	1.8V	STATUS	1.8V	STATUS	2.8V
43	NC	-	NC	-	NC	-	NC	-		
44	PON	-	NC	-	NC	-	NC	-		
45	GND	-	GND	-	GND	-	GND	-		
46	GPIO_07	1.8V	NC	-	MCCA3	-	MCCA3	-		
47	GPIO_08	1.8V	NC	-	MCCA2	-	MCCA2	-		
48	GPIO_09	1.8V	NC	-	MCCA1	-	MCCA1	-		

49	GPIO_10	1.8V	NC	-	MCCA0	-	MCCA0	-		
50	GPIO_11	1.8V	NC	-	MCCLK	-	MCCLK	-		
51	GPIO_12	1.8V	NC	-	MCCM0	-	MCCM0	-		
52	GPIO_24	1.8V	SIM2_DET	1.8V/3.0V	SIM2_DET	1.8V/3.0V	SIM2_DET	1.8V/3.0V		
53	SIM2_DATA	1.8V	SIM2_DATA	1.8V/3.0V	SIM2_DATA	1.8V/3.0V	SIM2_DATA	1.8V/3.0V		
54	GPIO_25	1.8V	SIM2_CLK	1.8V/3.0V	SIM2_CLK	1.8V/3.0V	SIM2_CLK	1.8V/3.0V		
55	GPIO_26	1.8V	SIM2_RST	1.8V/3.0V	SIM2_RST	1.8V/3.0V	SIM2_RST	1.8V/3.0V		
56	SIM2_VDD	1.8V	SIM2_VDD	1.8V/3.0V	SIM2_VDD	1.8V/3.0V	SIM2_VDD	1.8V/3.0V		
57	GPIO_01	1.8V	GPIO1	1.8V	GPIO1	1.8V	GPIO1	1.8V		
58	GPIO_02	1.8V	GPIO2	1.8V	GPIO2	1.8V	GPIO2	1.8V		
59	NC	-	NC	-	NC	-	NC	-		
60	1PPS	-	NC	-	NC	-	1PPS	-		
61	NC	-	NC	-	NC	-	GNSS_TXD	1.8V		
62	NC	-	NC	-	NC	-	GNSS_RXD	1.8V		
63	GND	-	GND	-	GND	-	GND	-		
64	I2C_SDA	-	SDA	-	I2C_SDA	-	I2C_SDA	-		
65	I2C_SCL	-	SCL	-	I2C_SCL	-	I2C_SCL	-		
66	GND	-	GND	-	GND	-	GND	-		
67	GND	-	GND	-	GND	-	GND	-		
68	ANT_GNSS	-	NC	-	NC	-	ANT_GNSS	-		
69	GND	-	GND	-	GND	-	GND	-		
70	GND	-	GND	-	GND	-	GND	-		
71	GND	-	GND	-	GND	-	GND	-		
72	GND	-	GND	-	GND	-	GND	-		
73	GND	-	GND	-	GND	-	GND	-		
74	GND	-	GND	-	GND	-	GND	-		
75	GND	-	GND	-	GND	-	GND	-		

76	GND	-	GND	-	GND	-	GND	-		
77	GND	-	GND	-	GND	-	GND	-		
78	GPIO_03	1.8V	GPIO3	1.8V	GPIO3	1.8V	GPIO3	1.8V		
79	GPIO_04	1.8V	GPIO4	1.8V	GPIO4	1.8V	GPIO4	1.8V		
80	GPIO_05	1.8V	GPIO5	1.8V	GPIO5	1.8V	GPIO5	1.8V		
81	GPIO_06	1.8V	GPIO6	1.8V	GPIO6	1.8V	GPIO6	1.8V		
82	BOOT_CFG●	1.8V	BOOT_CFG●	1.8V	BOOT_CFG●	1.8V	BOOT_CFG●	1.8V		
83	RESET	VBAT	RESET	VBAT	RESET	VBAT	RESET	VBAT		
84	DBG_RXD	1.8V	DBG_RXD	1.8V	DBG_RXD	1.8V	DBG_RXD	1.8V		
85	DBG_TXD	1.8V	DBG_TXD	1.8V	DBG_TXD	1.8V	DBG_TXD	1.8V		

NOTE

1. Bold lines indicate different pin functions.
2. The PIN Marked "●" cannot be pulled down before the module powered up. Otherwise, it will affect the normal start-up of the module.
3. GPIO3 and GPIO4 of A7683E/A7663E can be used as ANT tuner control (GRFC); GPIO_01 and GPIO_02 of A7681(A7665)E/SA/JP/NA can be used as ANT tuner control (GRFC).
4. For details information, please refer to each HD guide.

2.3 Top and Bottom View

The following figures show the top and bottom view of A7681(A7665)E/SA/JP/NA, A7682E, A7683E and SIM800C.

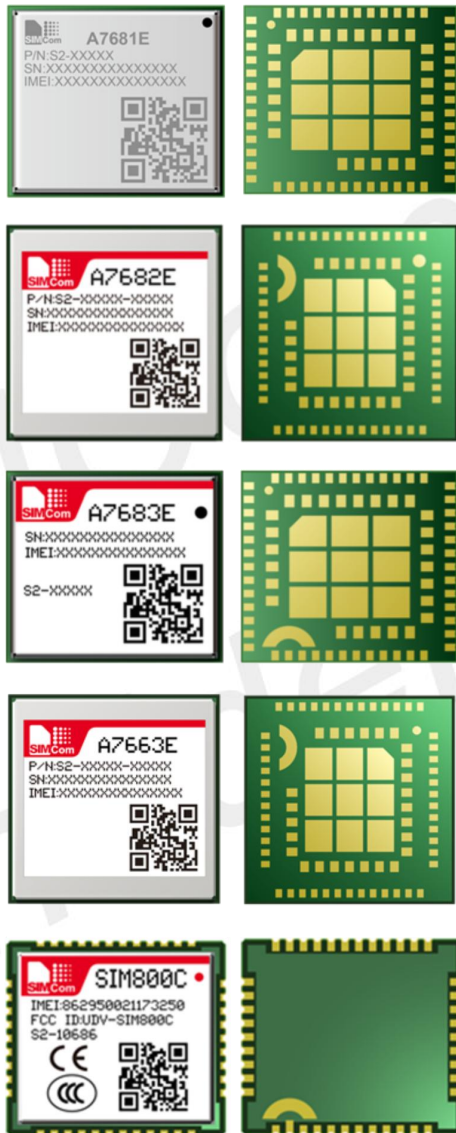

Figure 2:A7681(A7665)E/SA/JP/NA、 A7682E/A7683E/A7663E/SIM800C top and bottom view

NOTE

The above is the design effect drawing of the module for reference, and the actual appearance shall prevail in kind.

2.4 Recommended PCB footprint outline

The recommended PCB footprint outline for A7681(A7665)E/SA/JP/NA, A7682E, A7683E, A7663E and SIM800C is shown as follows.

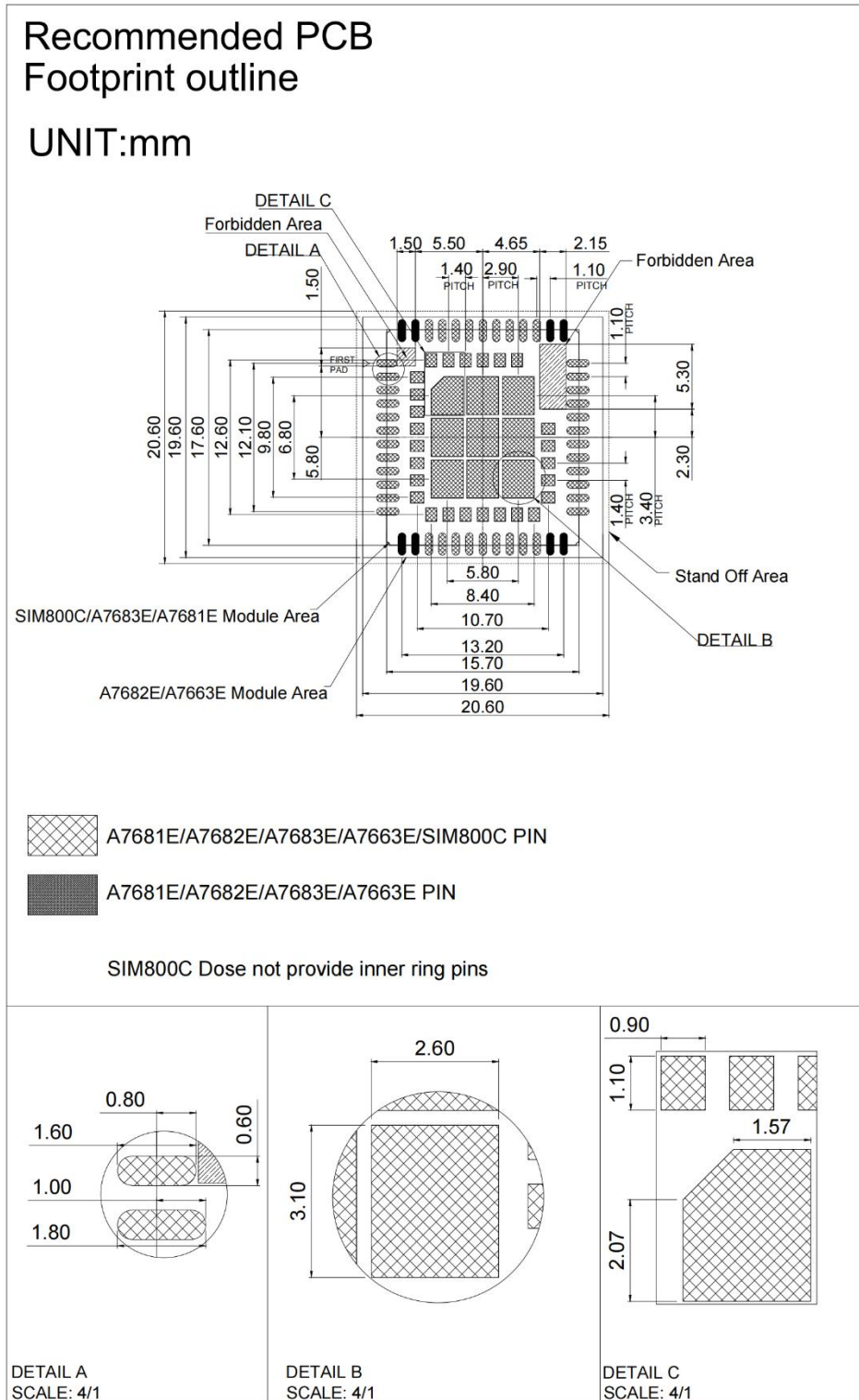

Figure 3: Recommended PCB footprint outline (Unit: mm)

2.5 Recommended SMT Stencil

The recommended SMT Stencil of A7681(A7665)E/SA/JP/NA and A7683E is shown as follows.

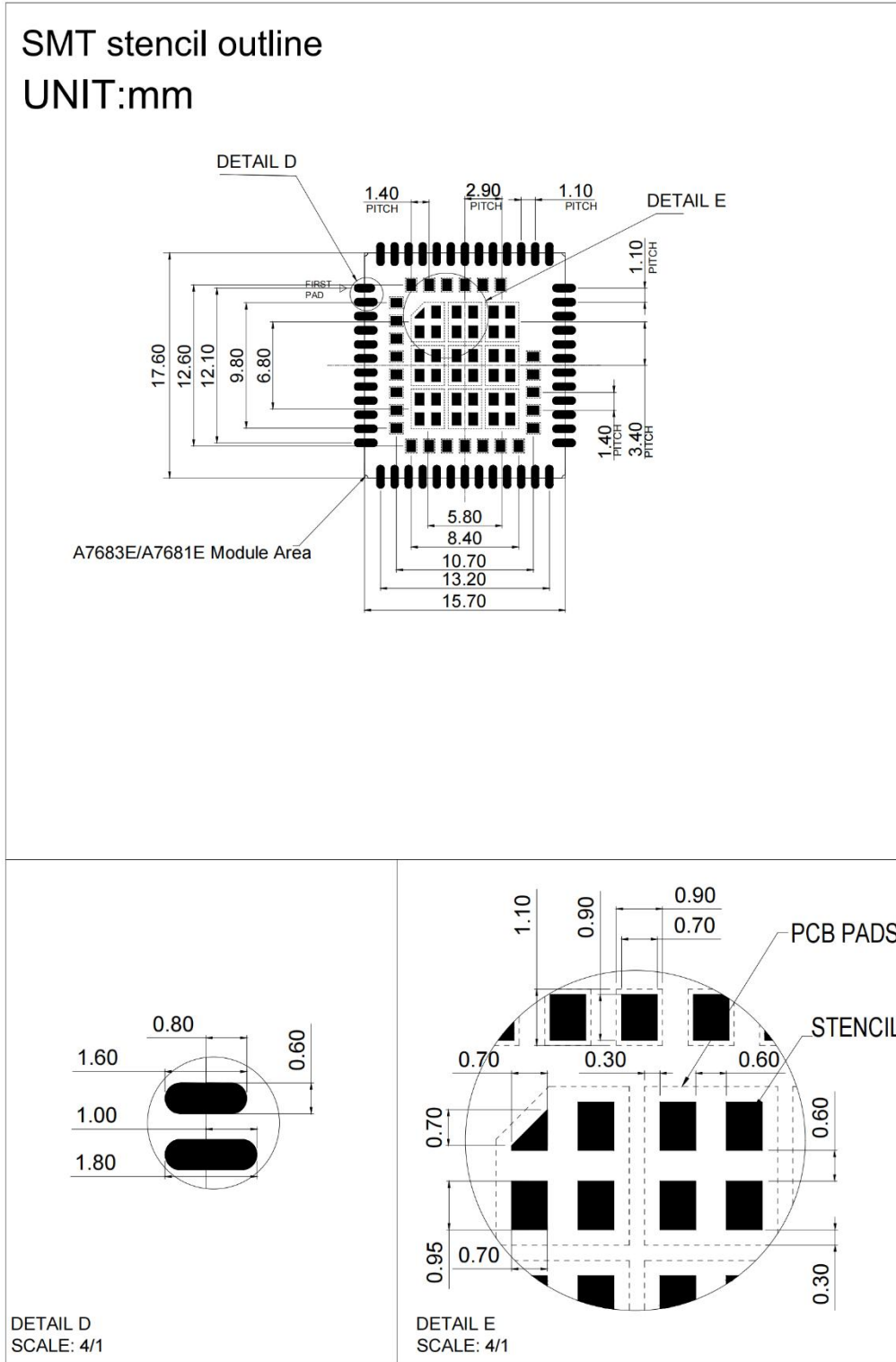

Figure 4: Recommended SMT stencil of A7681E and A7683E (Unit: mm)

The recommended SMT Stencil of A7682E and A7663E is shown as follows.

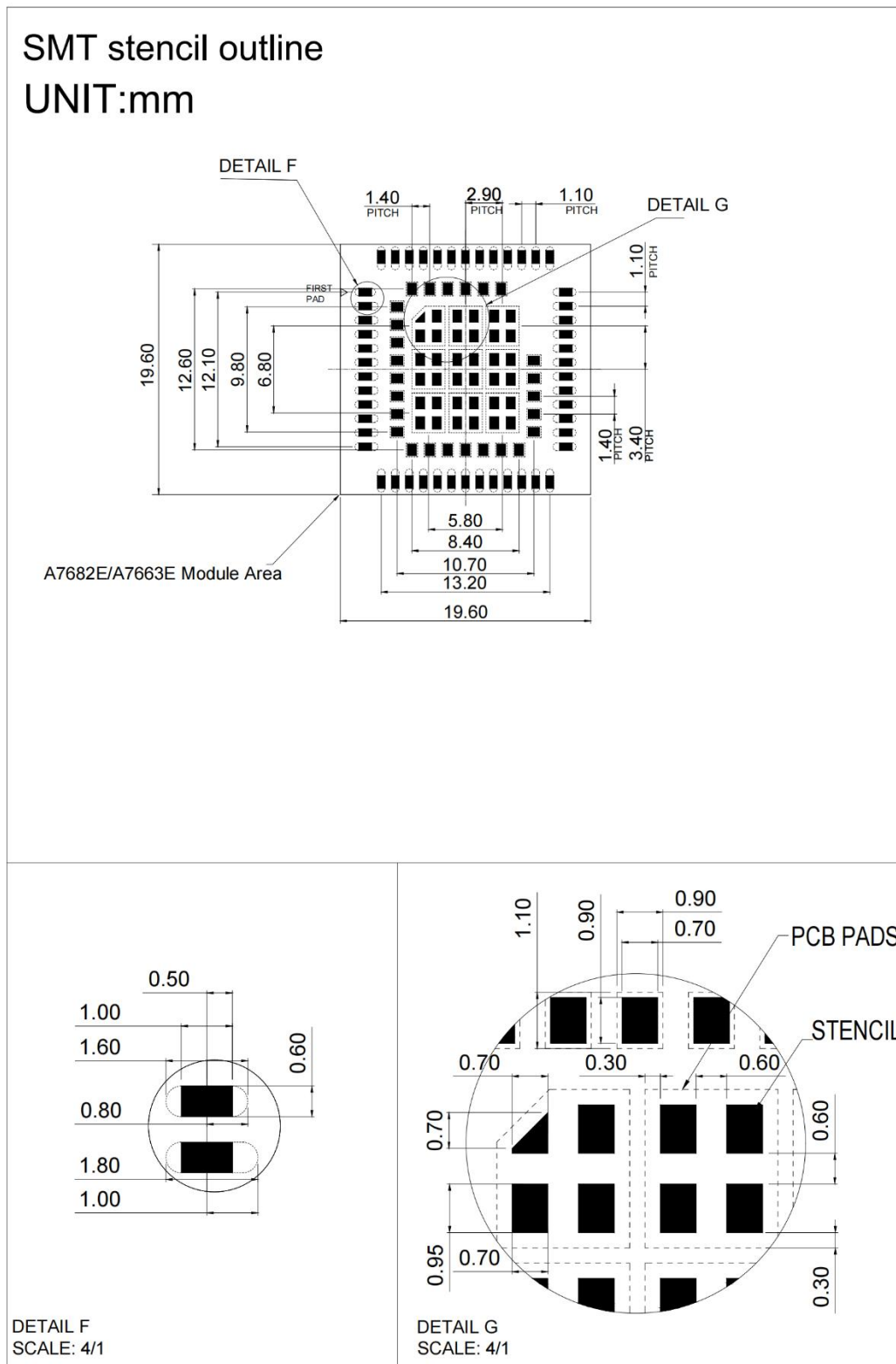

Figure 5: Recommended SMT stencil of A7682E and A7663E (Unit: mm)

The recommended SMT Stencil of SIM800C is shown as follows.

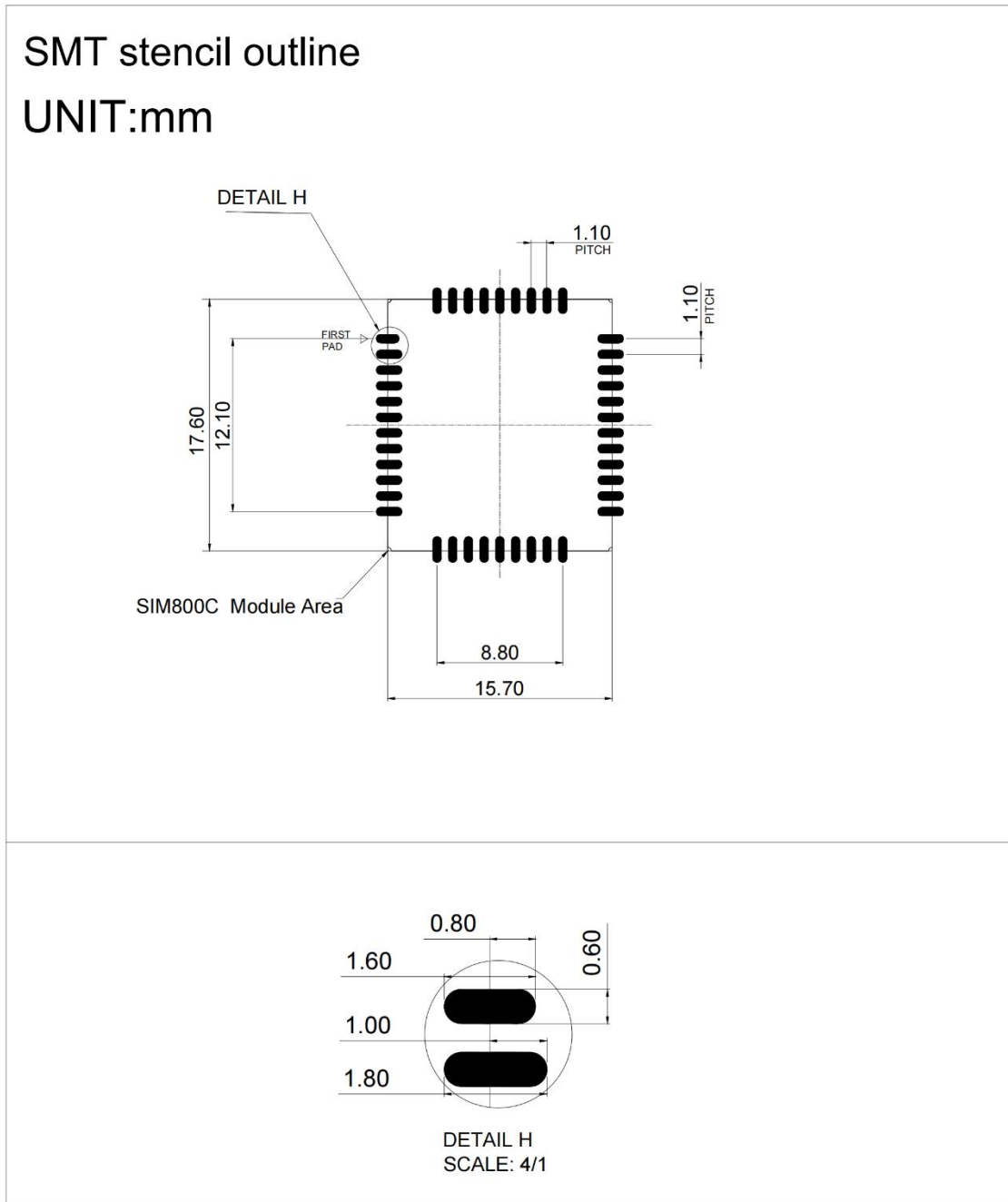

Figure 6: Recommended SMT stencil of SIM800C (Unit: mm)

2.6 PIN Size Comparison

The pin sizes of different modules vary. The specific size comparison is shown as follows:

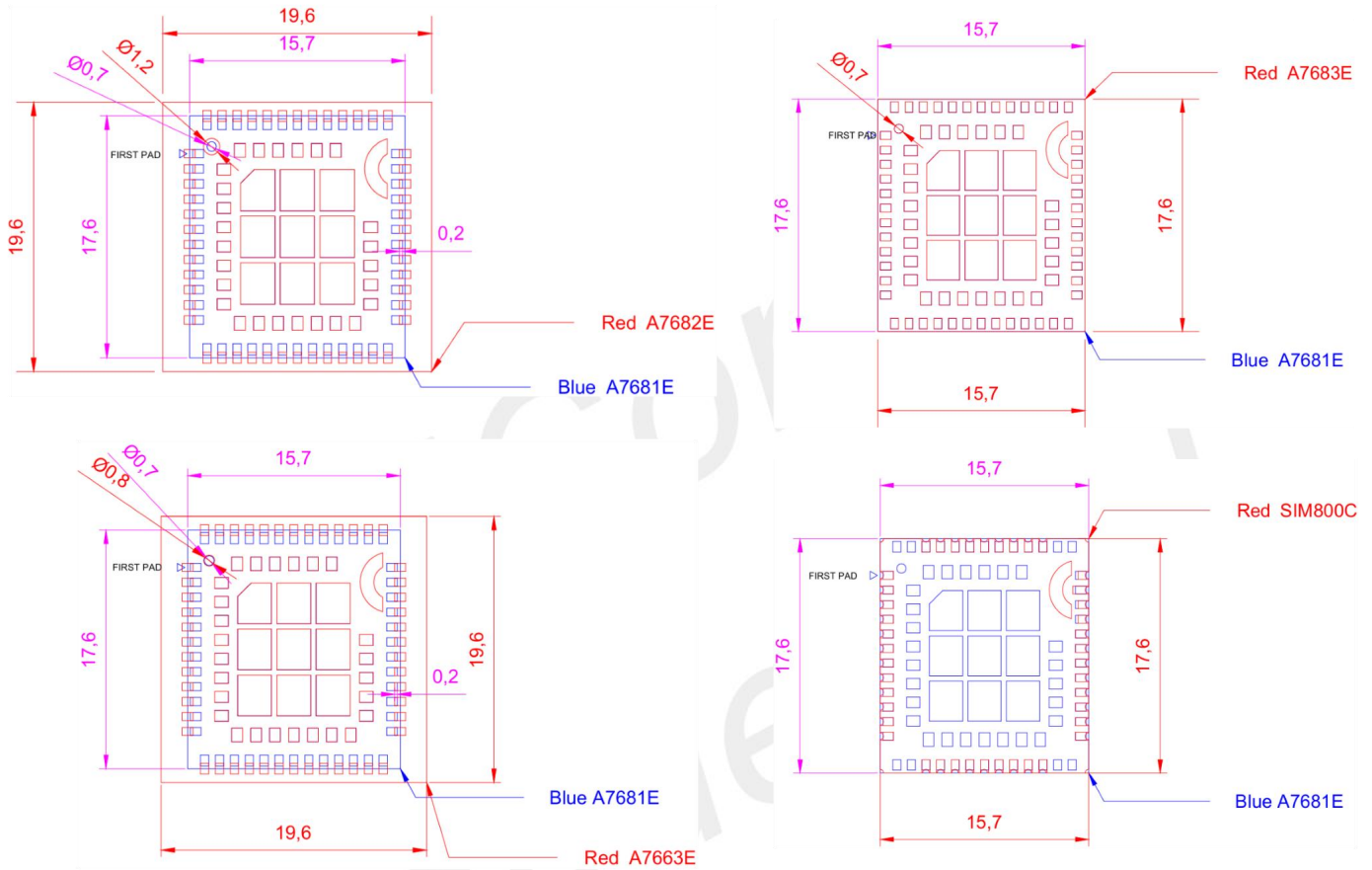

Figure 7: Comparison of PIN Size of A7681(A7665)E/SA/JP/NA

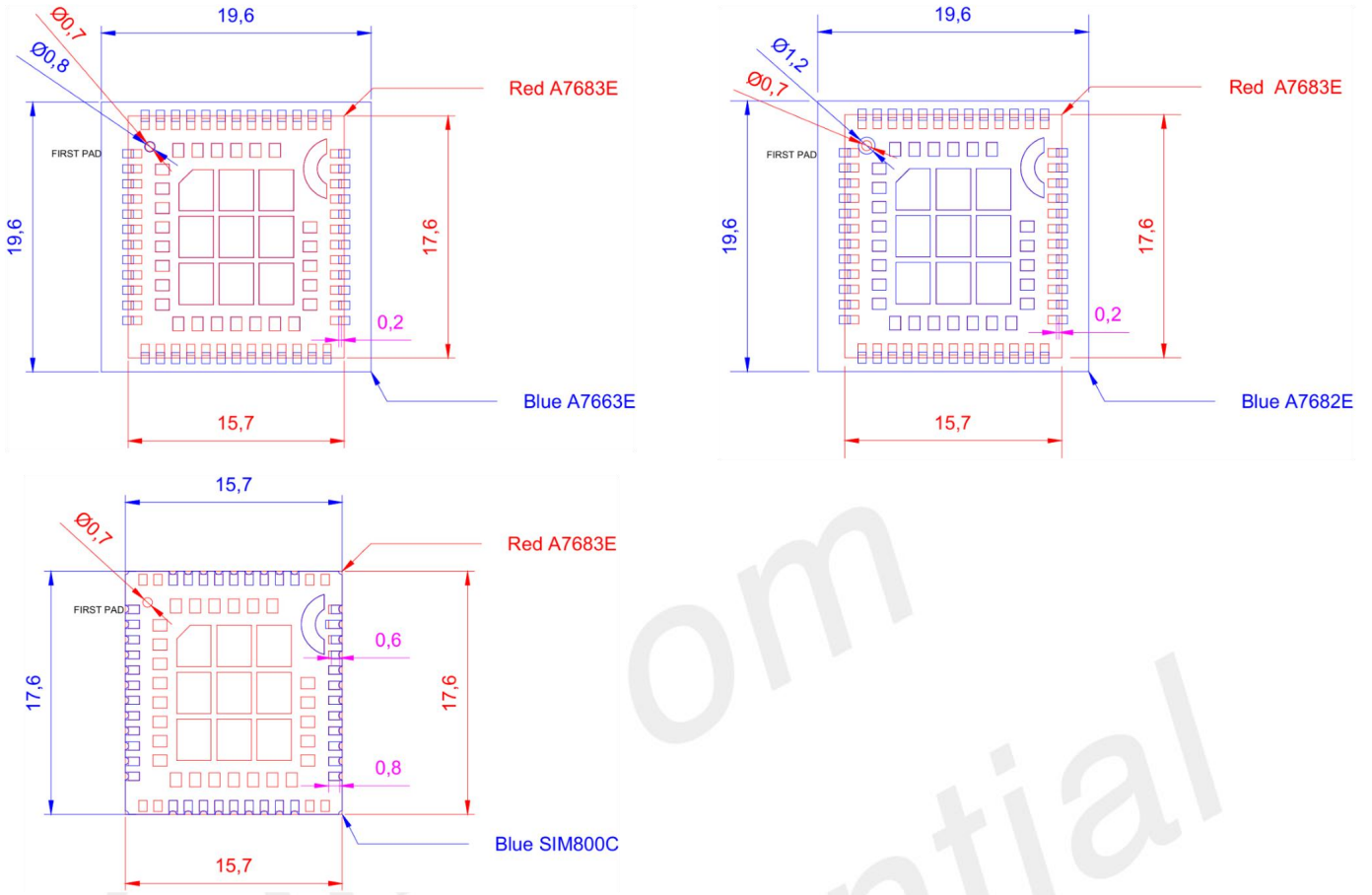

Figure 8: Comparison of PIN Size of A7683E

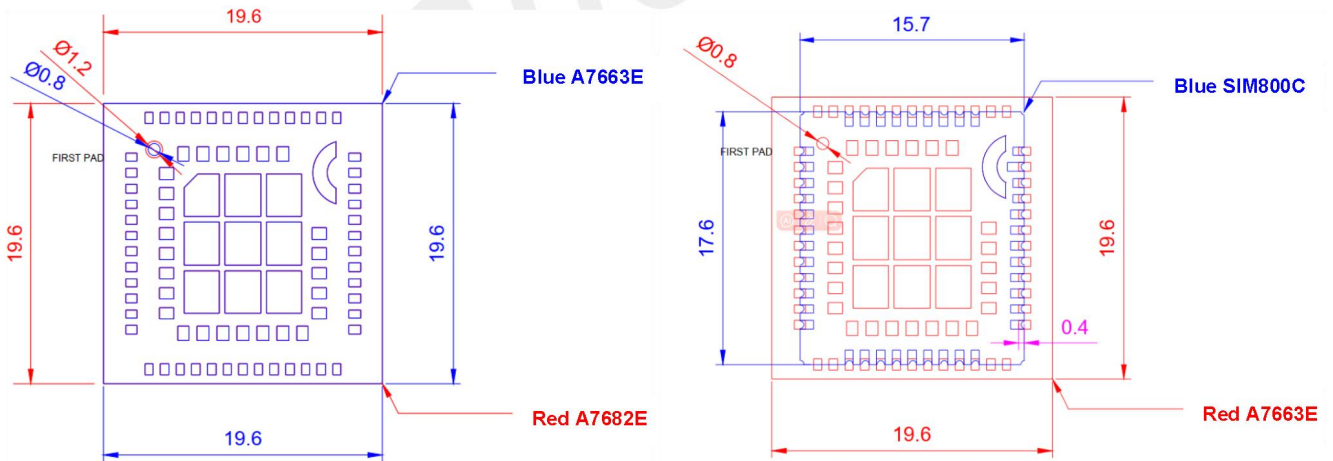

Figure 9: Comparison of PIN Size of A7663E

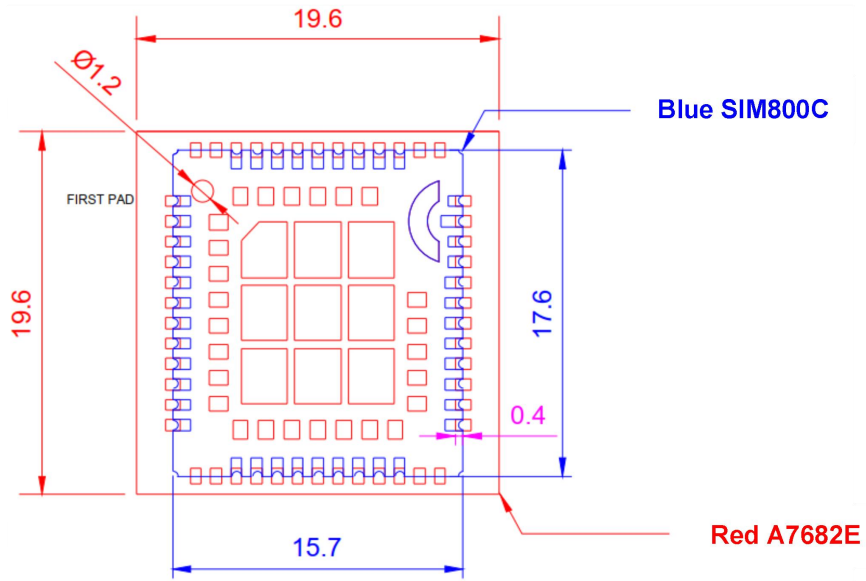

Figure 10: Comparison of PIN Size of A7682E and SIM800C

SIMCOM
Confidential

3 Hardware Reference Design

Customers using A7681(A7665)E/SA/JP/NA, A7682E, A7683E, A7663E and SIM800C interface can refer to the design in this chapter.

3.1 Power Supply

The following table shows the power supply voltage range of A7681(A7665)E/SA/JP/NA, A7682E, A7683E, A7663E and SIM800C.

Table 5: Module recommended supply voltage comparison

Modules	Power Pin	Symbol Description	Min	Typical	Max	Unit
A7681(A7665)E/SA/JP/NA	VBAT	Power supply range	3.3	3.8	4.2	V
A7682E	VBAT	Power supply range	3.4	3.8	4.2	V
A7683E	VBAT	Power supply range	3.4	3.8	4.2	V
A7663E	VBAT	Power supply range	3.4	3.8	4.2	V
SIM800C	VBAT	Power supply range	3.4	4.0	4.4	V

For better RF performance and system stability, it is suggested to position four ceramic capacitors (10pF/33pF/0.1uF/1uF) near VBAT. Additionally, it is advised to have a VBAT layout routing width of at least 2mm from the power supply on the PCB to the module. Please refer to the recommended design layout below.

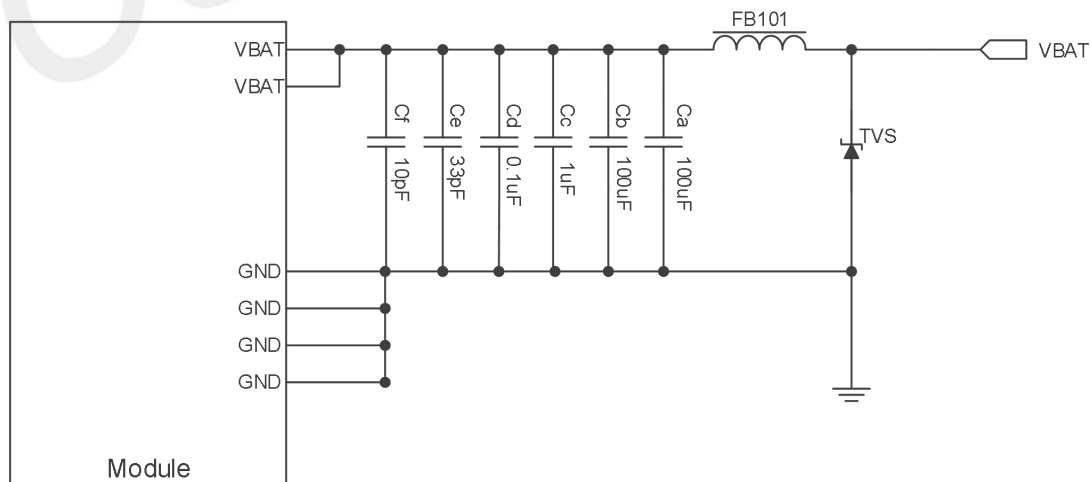

Figure 11: Power supply application circuit

3.1.1 A7681(A7665)E/SA/JP/NA

When the module is transmitting at maximum power in LTE mode, the current can reach up to a peak current, In order to ensure that the voltage drop is less than 300mV, please ensure that the external power supply capacity is no less than 1.2A.

In the customer's design, special attention must be paid to the design of the power supply. If the voltage drops below 3.3V, the RF performance of the module will be affected, the module will shut down if the voltage is too low. It is recommended to select an LDO or DC-DC chip with an enable pin, and the enable pin is controlled by the MCU.

3.1.2 A7682E

When the A7682E module is at the maximum power in GSM TX mode, the peak current can reach 2A (peak current), which results in a significant voltage drop on VBAT. To ensure that the voltage drop is less than 300mV, the power supply capacity of the external power supply must be no less than 2A.

In the customer's design, ensure that the voltage on the VBAT pins will never drop below 3.4V, even when the module current consumption reaches 2A. If the voltage drops below 3.4V, the RF performance of the module will be affected. Selecting an LDO or DC-DC chip with an enable pin is recommended, and the MCU controls the enable pin.

The following figure shows the VBAT voltage drop.

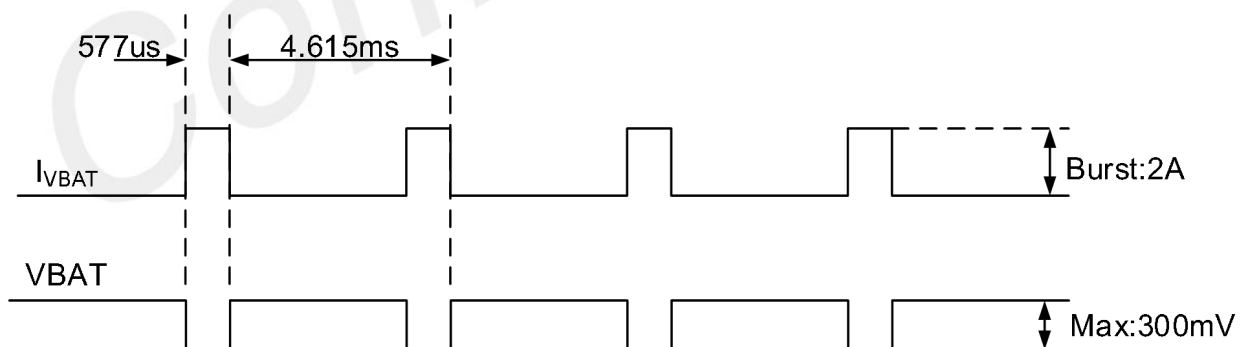

Figure 12: Burst current cause VBAT drop

3.1.3 A7683E/A7663E

When the A7683E/A7663E is transmitting at maximum power in LTE mode, the continuous current can

reach up to 700mA, resulting in a significant voltage drop on the VBAT. In order to ensure that the voltage drop is less than 300mV, the power supply capacity of the external power supply must be no less than 1A. In the customer's design, special attention must be paid to the design of the power supply. If the voltage drops below 3.4V, the RF performance of the module will be affected, the module will shut down if the voltage is too low. It is recommended to select an LDO or DC-DC chip with an enable pin, and the enable pin is controlled by the MCU.

3.1.4 SIM800C

During the 2G transmission process, the instantaneous current of the SIM800C reached as high as 2A. The battery terminal burst current and voltage drop model are shown in the figure below:

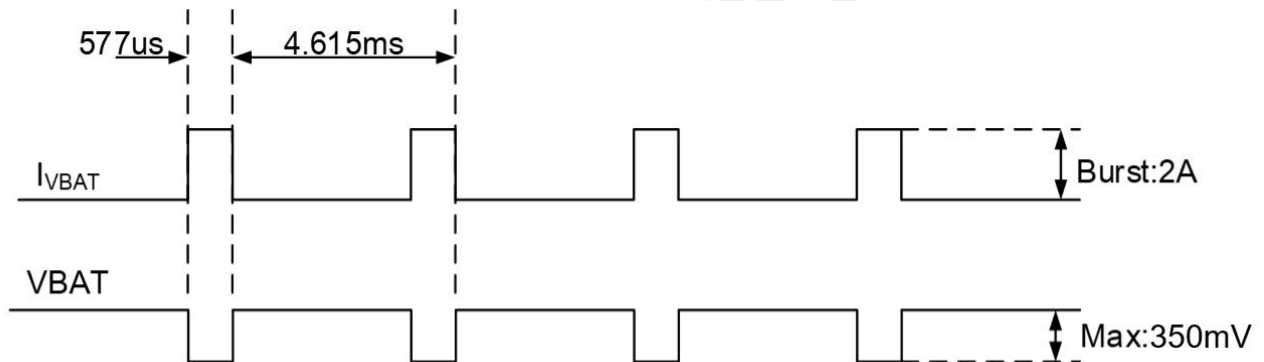

Figure 13: Burst transmission power requirements (SIM800C)

When designing the power supply in customers' applications, pay special attention to power losses. Ensure the input voltage never drops below 3.0V, even when current consumption rises to 2A in the transmit burst. If the power voltage drops below 3.0V, the module may be shut down automatically. The PCB traces from the VBAT pins to the power supply must be wide enough (at least 60mil) to decrease voltage drops in the transmit burst. The power IC and the bypass capacitor should be placed on the module as close as possible.

3.2 Power on/off and Circuit

The 39 pin of A7681(A7665)E/SA/JP/NA, A7682E, A7683E, A7663E and SIM800C is PWRKEY. A7681(A7665)E/SA/JP/NA, A7682E, A7683E, A7663E and SIM800C can be turned on by driving the PWRKEY pin to a low level for a certain time. Using an open drain or collector driver is recommended to control the PWRKEY. A reference circuit is shown below.

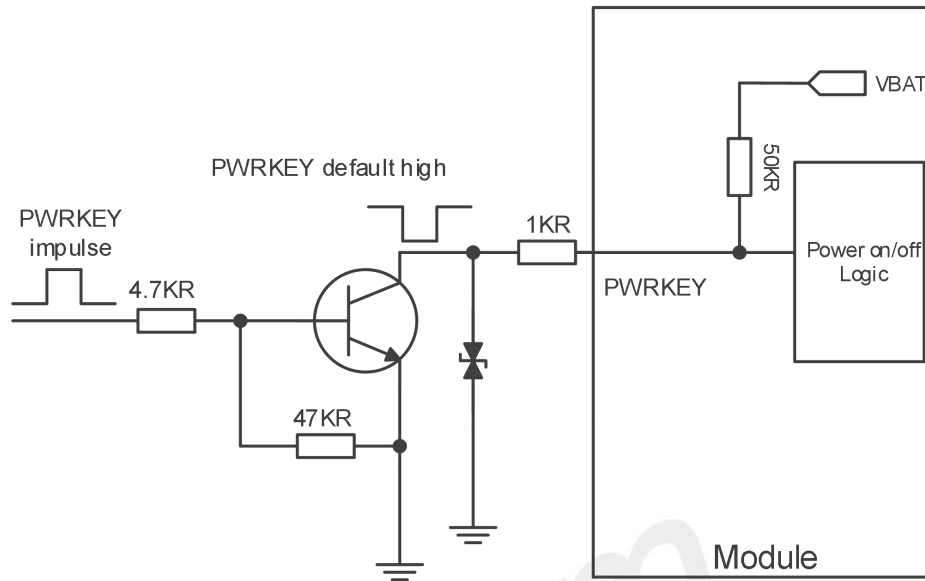

Figure 14: Power on/off reference circuit

The module has the following shutdown methods:

- Power off by pulling the PWRKEY pin down to a low level
- Power off Module by AT command.
- Over-temperature or under-temperature automatic power off.
- Over-voltage or under-voltage automatic power off, 'AT+CPMVT' set voltage range (A7682E and A7683E).

Customers are strongly recommended to use PWRKEY or AT command to shut down, then power off VBAT after shutting down (especially when the module does not need to work at all). In addition, turning off the VBAT directly by disconnecting the VBAT may cause damage to the FLASH.

NOTE

1. The AT command to power off the module SIM800C: AT+CPOWD=1, A7681(A7665)E/SA/JP/NA、A7682E/A7683E/A7663E: AT+CPOF.
2. The customer's circuit design must have the function that the master can control the power on/off of the module.
3. When the temperature exceeds the range of - 30 ~ + 80℃, A7682E will report warning information through the AT port; When the temperature exceeds the range of - 30 ~ + 75℃, A7681(A7665)E/SA/JP/NA、A7683E/A7663E will report warning information through the AT port. When the temperature exceeds the range of - 40 ~ + 85℃, A7681(A7665)E/SA/JP/NA、A7682E/A7683E/A7663E will shut down automatically. For a detailed description of 'AT+ CPOF' and 'AT+ CPMVT', please refer to the AT command manual.

3.3 Reset Circuit

The pin 83 of A7681(A7665)E/SA/JP/NA、 A7682E/A7683E/A7663E is RESET pin. These reset circuit is as follows: the customers reset the module by pulling down the RESET pin.

Pay attention to that PIN 28 of SIM800C is VRTC function. Current input for RTC when the VBAT is not supplied for the system. Current output for backup battery when the VBAT power supply is in present and the backup battery is in low voltage state. The RTC power supply of module can be provided by an external capacitor or a battery (non-chargeable or rechargeable) through the VRTC. The following figures show various reference circuits for RTC back up.

The PWRKEY pin of SIM800C has a reset function. The module will reset the system when PWRKEY is pulled down for a certain period. Therefore, connecting PWRKEY to GND directly or to GND through a 0R resistor is not recommended when designing external circuits.

The recommended circuit of the pin 83 (A7681E/A7682E/A7683E/A7663E) is as follows:

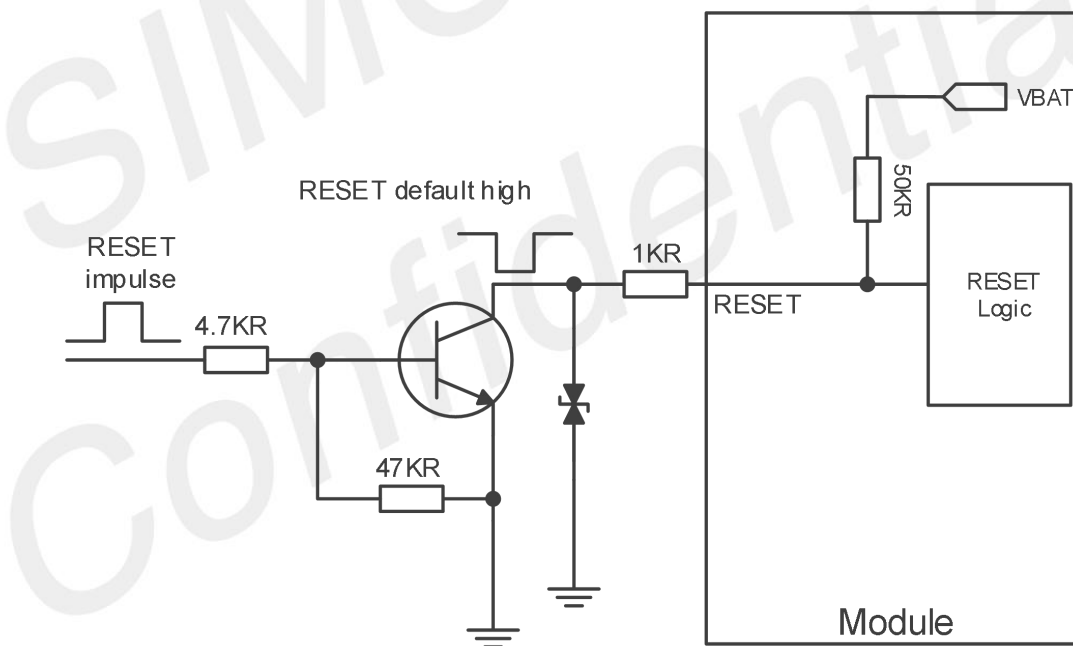

Figure 15:A7681(A7665)E/SA/JP/NA、 A7682E/A7683E/A7663E Reset reference circuit

The recommended circuit of the pin 28 (SIM800C) is as follows:

- External capacitor backup

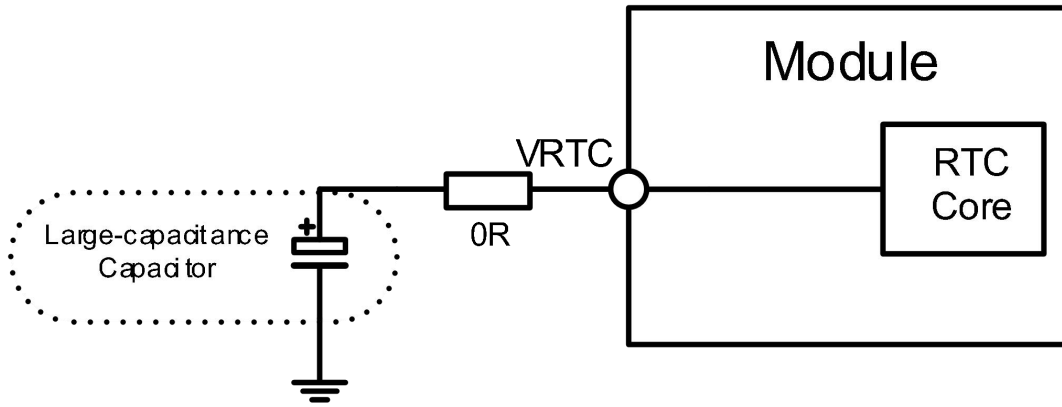

Figure 16: SIM800C PIN 28 reference circuits (RTC supply from capacitor)

- External capacitor backup

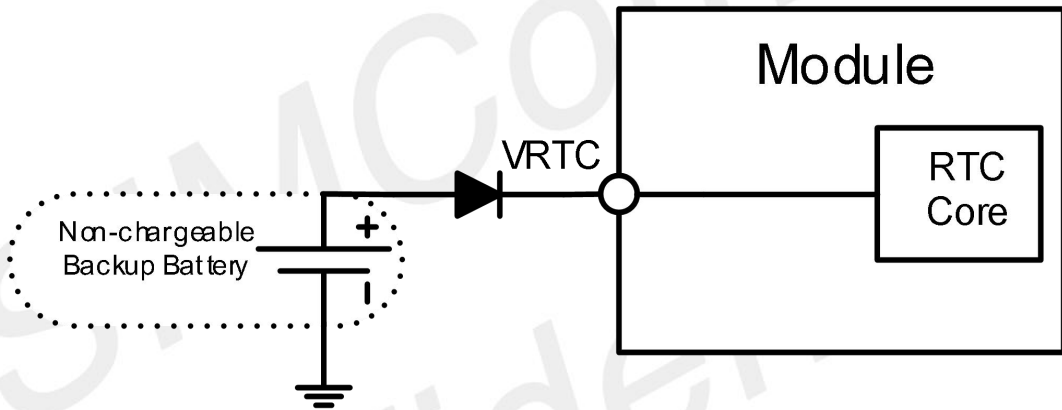

Figure 17: SIM800C PIN 28 reference circuits (non-chargeable battery)

- External capacitor backup

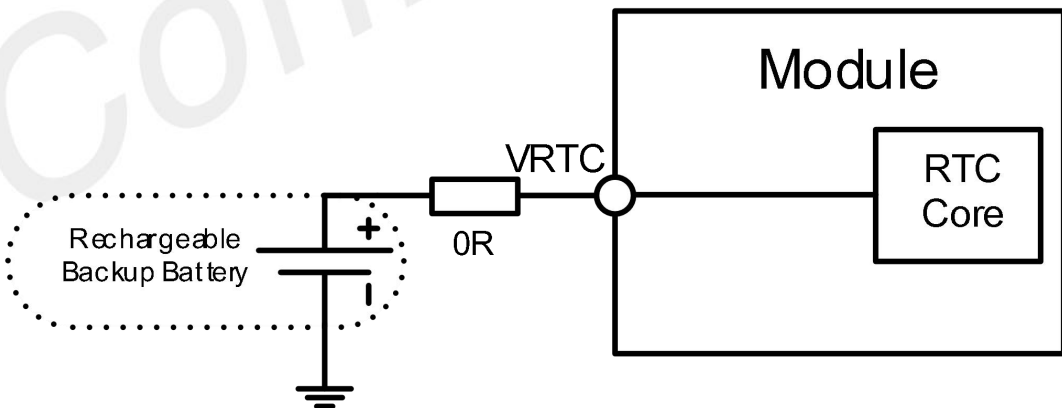

Figure 18: SIM800C PIN 28 reference circuits (rechargeable battery)

NOTE

1. When PWRKEY is pulled down ($1.5S < T < 2S$), SIM800C module will reset.
2. For more information, please refer to each HD guide.

3.4 USB Interface

A7681(A7665)E/SA/JP/NA, A7682E, A7683E, A7663E and SIM800C module provide a USB2.0 interface, supporting high-speed 480Mbps and full-speed mode 12Mbps, and do not support USB charging function; A7681(A7665)E/SA/JP/NA、A7682E/A7683E/A7663E does not support USB HOST mode.

USB is the main debugging port and software upgrade interface. It is recommended that customers reserve USB test points during design. If the main control chip is connected, reserving a 0R resistor for switching external test points during design, as shown in the figure below.

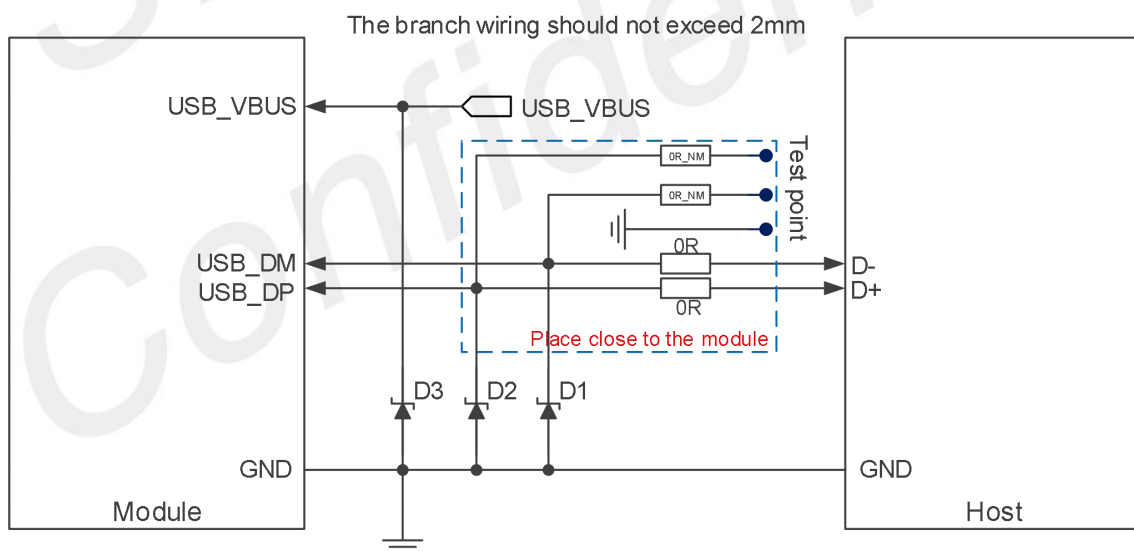

Figure 19: USB reference circuit

Customers should pay attention to the selection of D3 devices. It is recommended to choose anti-static and anti-surge two-in-one devices, and one TVS tube can be placed, the recommended models of D3 are listed in Table 7. D+/D- trace impedance is controlled according to 90Ω and covered with ground; D1/D2 select TVS tube with capacitance value $< 1\text{pf}$, and they should be placed near the USB connector or test point, The recommended models of D1 and D2 are listed in Table 6.

Table 6: TVS for USB part number list

Manufacturer	Part Number	V_{RWM}	V_{Cmax}	C_{Jmax}	Package
WILL	ESD73131CZ-2/TR	5V	6.5V	0.45pF	DWN0603-2L
ON	ESD9L5.0ST5G	5V	9.8V	0.9pF	SOD-923
NXP	PESD5V0F1BSF	5V	10V	0.3pF	DSN0603-2
AMAZING	AZ9707-01F	7V	12.5V	950pF	DFN1610

Table 7: Recommended TVS Diodes for VBUS

Manufacturer	Part Number	V_{RWM}	V_{Cmax}	C_{Jmax}	Package
WAYON	WS07DP	7V	20V	1000pF	DFN1610-2L
PRISEMI	PTVSHC2EN7VU	7V	24V	750pF	DFN1610-2L
BILLSEMI	BLE7V065B6U	7V	16V	500pF	DFN1610-2L
LRC	LTVS16H7.0T5G	7V	15V	750pF	DFN1610

3.5 UART Interface

A7681(A7665)E/SA/JP/NA、A7682E/A7683E/A7663E provides 3 serial ports, one main full-function communication serial port UART (RTS/CTS flow control function debugging), one ordinary two-wire serial port (UART3), one print LOG serial port (Debug_UART), and the module is a DCE (Data Communication Equipment) device.

SIM800C provides two sets of serial ports: one main full-function communication serial port UART1 (support RTS/CTS flow control function debugging) and one set of ordinary serial ports, which can be used for external devices. The module is DCE (Data Communication Equipment).

Below are the reference circuits.

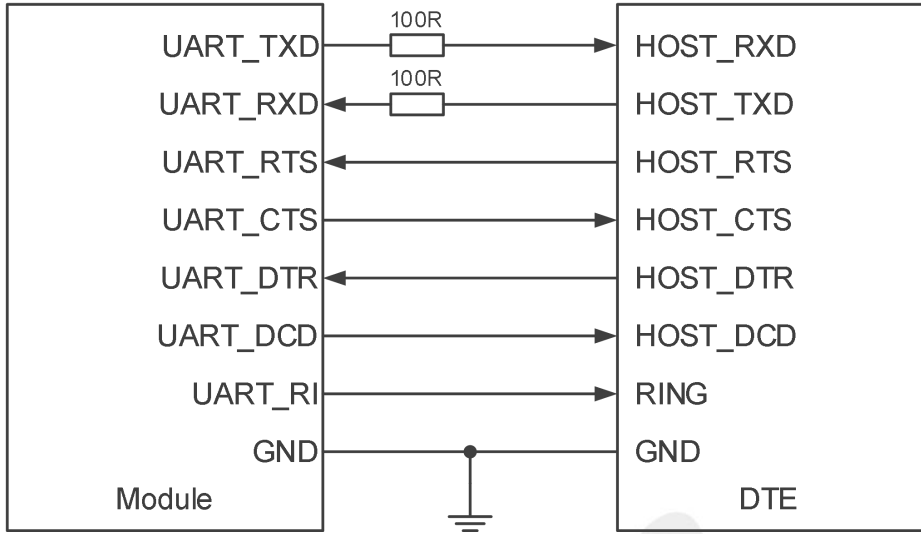

Figure 20: UART Full modem

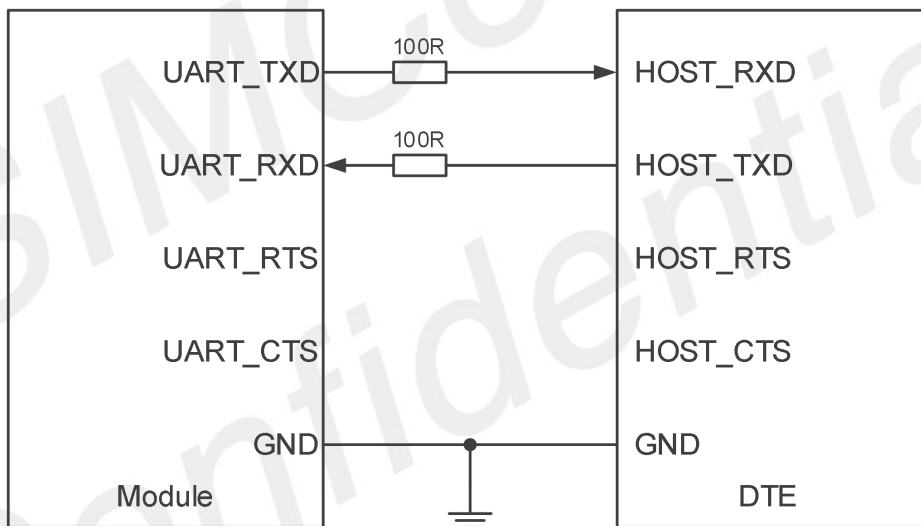

Figure 21: UART Null modem

The following figure shows the use of a transistor for circuit conversion. The circuit in the dotted line can refer to the circuit of the solid line TXD and RXD, and you need to pay attention to the direction of the signal.

The recommended transistor model here is MMBT3904.

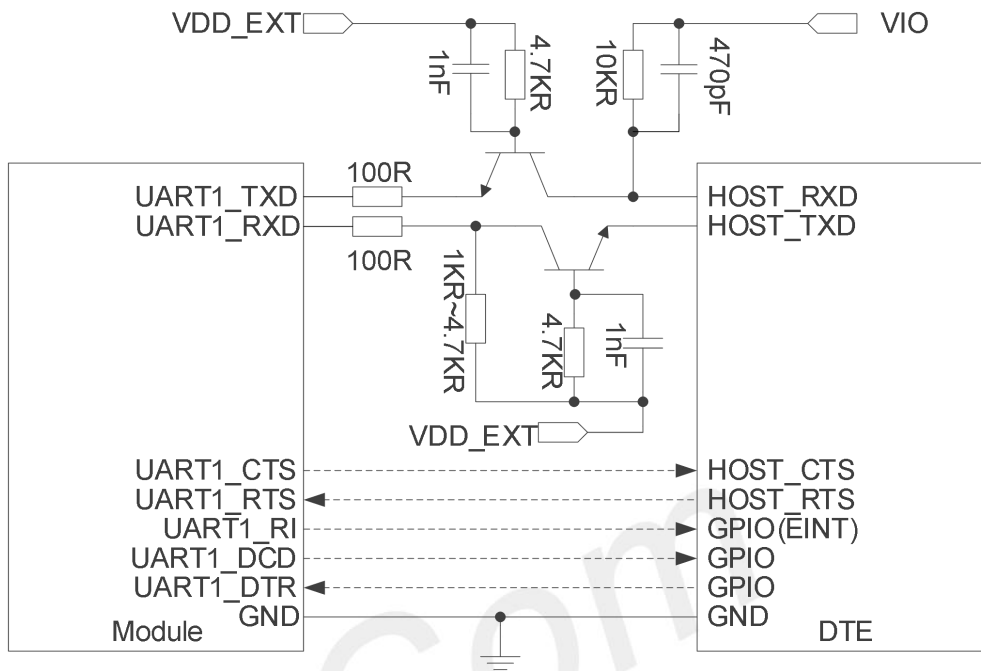

Figure 22: Triode level conversion circuit

When the level translator chip is used to connect the module and the host (the interface level does not match), the recommended model for level conversion chip is TXS0108EPWR, the reference design is shown as followed.

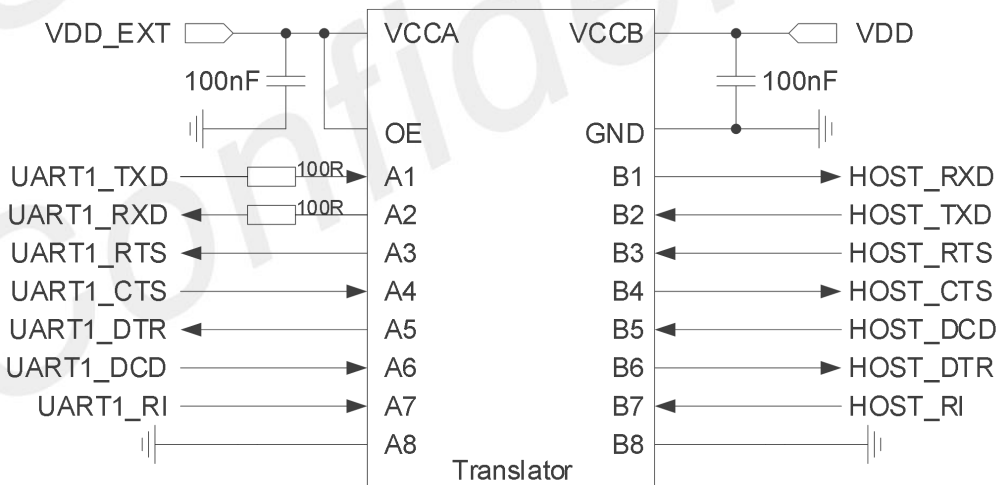

Figure 23: Triode level conversion circuit

NOTE

1. The VDD_EXT of each project in the diagram is different. For more information, please refer to each HD guide.
2. The GNSS serial port of A7663E has been internally connected to UART3.
3. For more information, please refer to each HD guide.

3.6 USIM Interface

A7681(A7665)E/SA/JP/NA, A7682E, A7683E, A7663E and SIM800C support 1.8V/3.0V (U)SIM card by default and support hot-swappable function.

The recommended circuit is as follows:

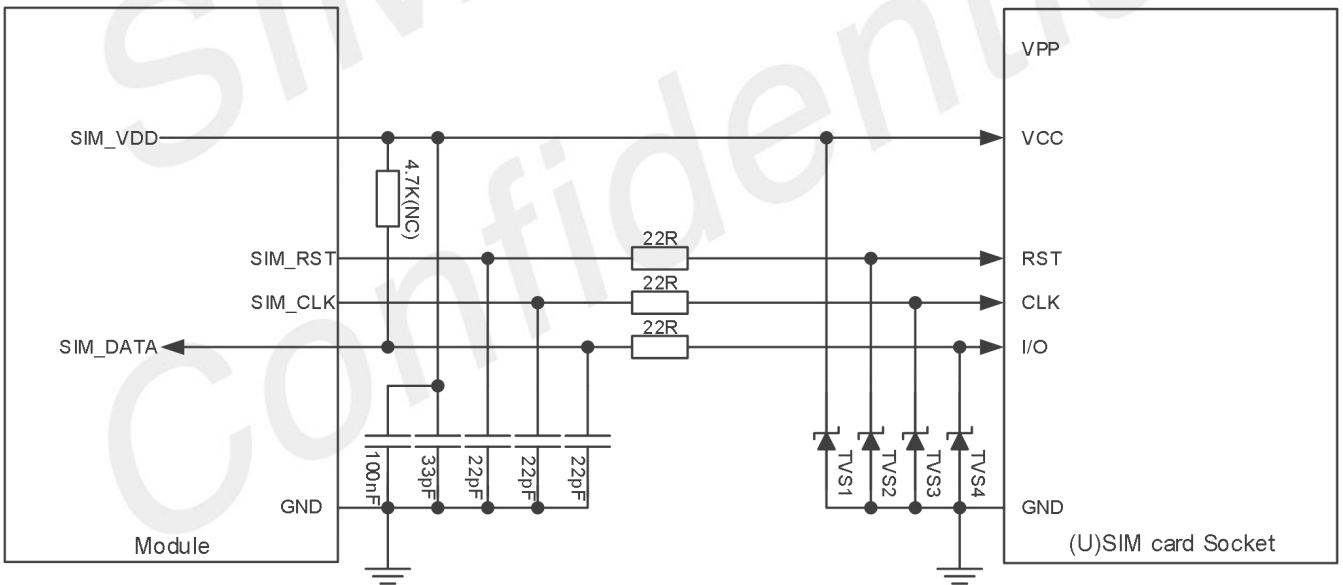

Figure 24: SIM interface reference circuit (6PIN)

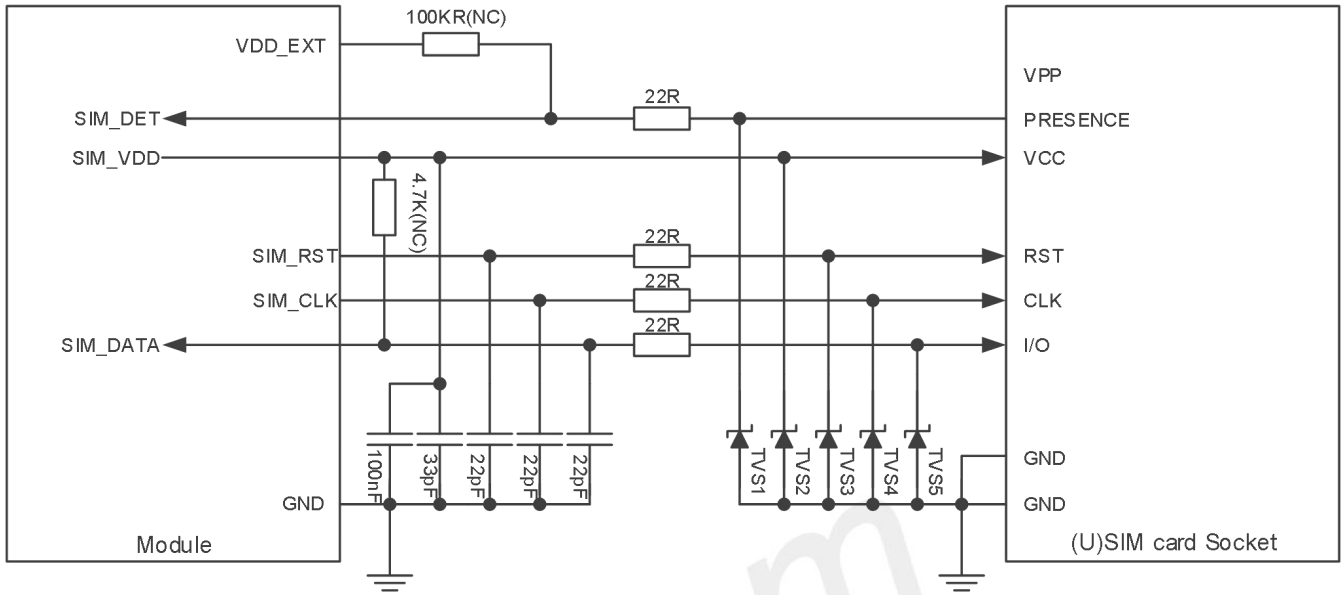

Figure 25: SIM interface reference circuit (8PIN)

Table 8: TVS for USIM socket part number list

Manufacturer	Part Number	V_{RWM}	V_{Cmax}	P_{PPmax}	C_{Jmax}	Package
WAYON	WS03DTUMS-B	3.3V	8V	35W	0.7pF	DFN0603-2L
WILL	ESD9X5VU-2/TR	5V	8V	72W	0.9pF	DFN1006-2L

NOTE

1. A7681(A7665)E/SA/JP/NA, A7682E, A7683E and A7663E support two SIM card interfaces.
2. For more information, please refer to each HD guide.

3.7 SD/MMC Interface

A7683E and A7663E provides SD/MMC interface, which supports 208MHz SDR and 50MHz DDR clock frequency and 128GB SD.

Following mode are supported: DS, HS, HS200, SDR12, SDR25, SDR50, SDR104, and DDR50.

Conforming to specifications: SDIO Card Specification version 3.0, eMMC Specification version 4.5.

The recommended reference design is as follows:

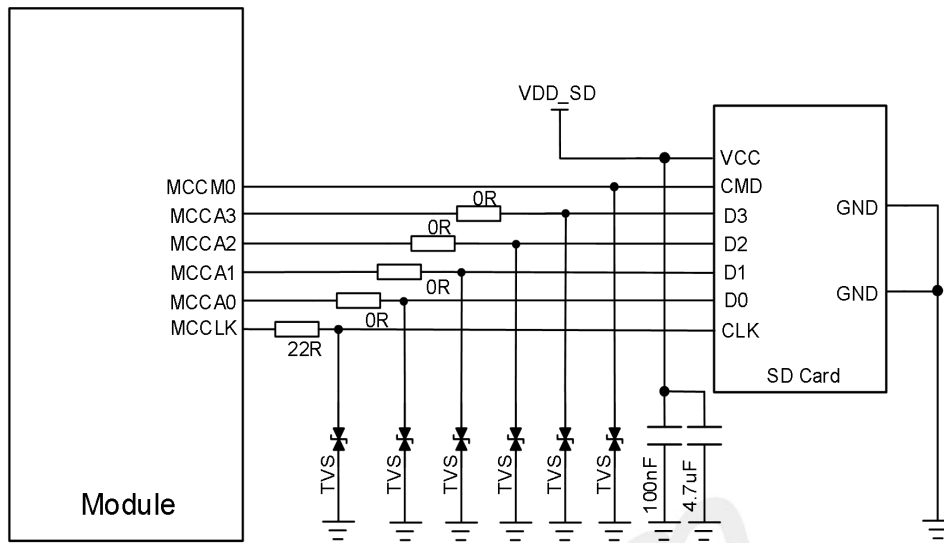

Figure 26: SD/MMC interface recommendation circuit for A7683E/A7663E

3.8 Audio Interface

A7682E/A7683E/A7663E/SIM800C provides 1 channel of analog audio MIC input interface and 1 channel of analog audio SPK output interface. A7681E only provides 1 channel of analog audio SPK output interface. Customers can connect to an external Speaker for voice calls or multimedia playback. (A7681E does not support voice calls.)

The following circuit is the reference design.

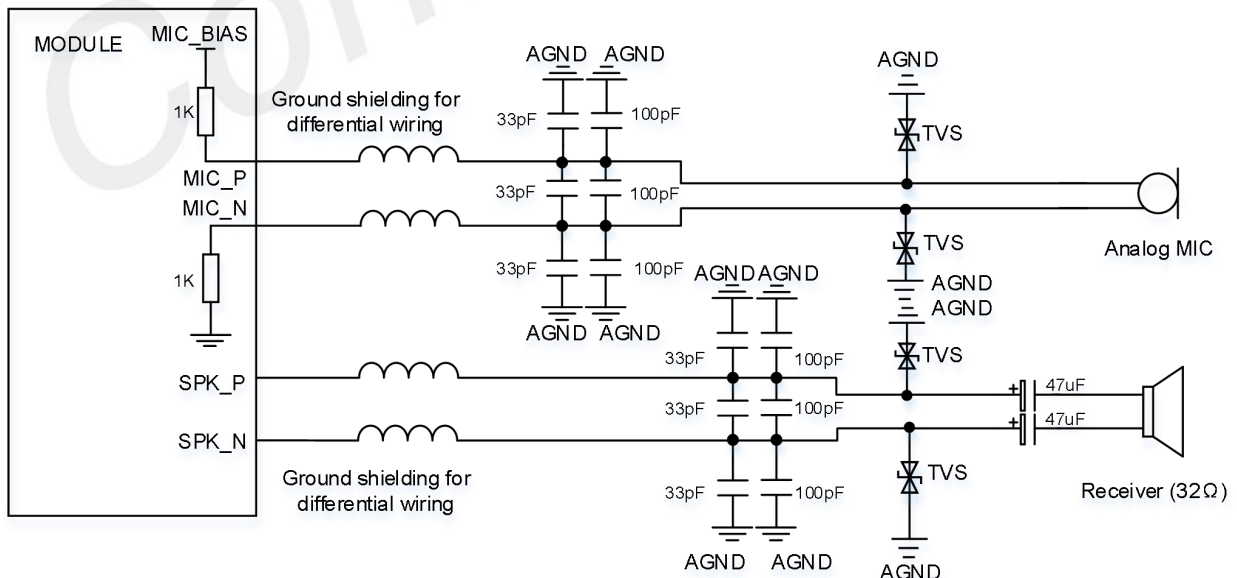

Figure 27: Analog audio recommendation circuit for A7683E/A7663E/SIM800C

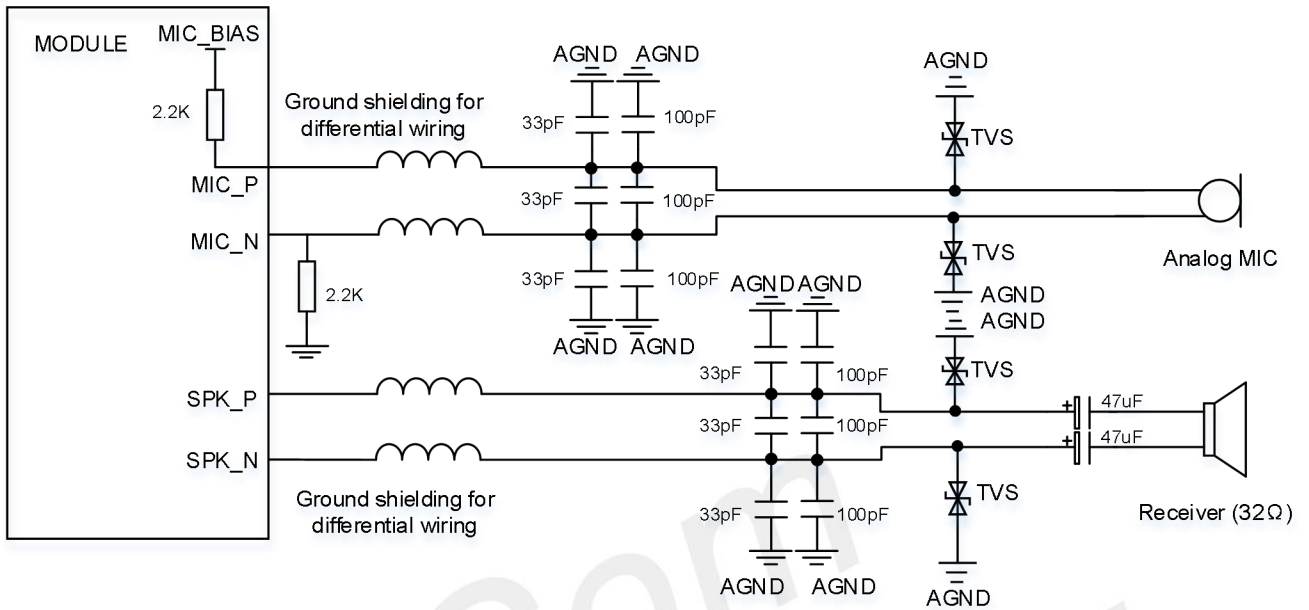

Figure 28: Analog audio recommendation circuit for A7682E

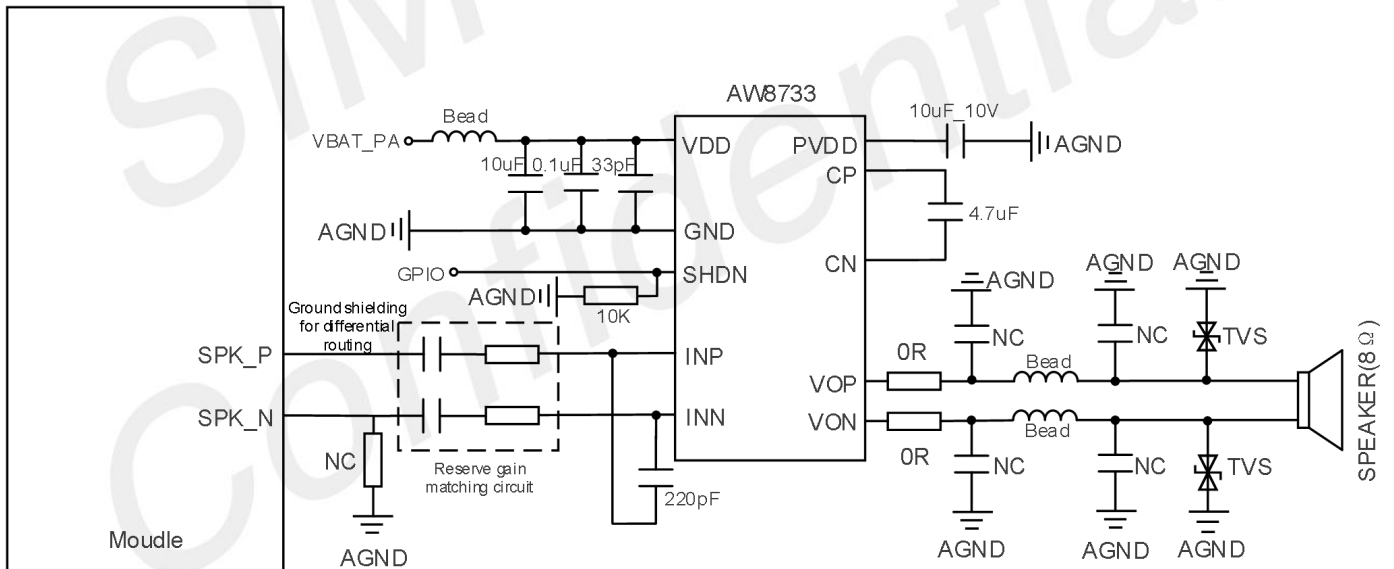

Figure 29: Analog audio recommendation circuit for A7681(A7665)E/SA/JP/NA

NOTE

1. The MICN circuit of A7682E requires an external resistor.
2. For more information, please refer to each HD guide.

3.9 Network/STATUS Indication

The NETLIGHT/STATUS pin drives the network status and module status indication LED. The following circuit is the reference design.

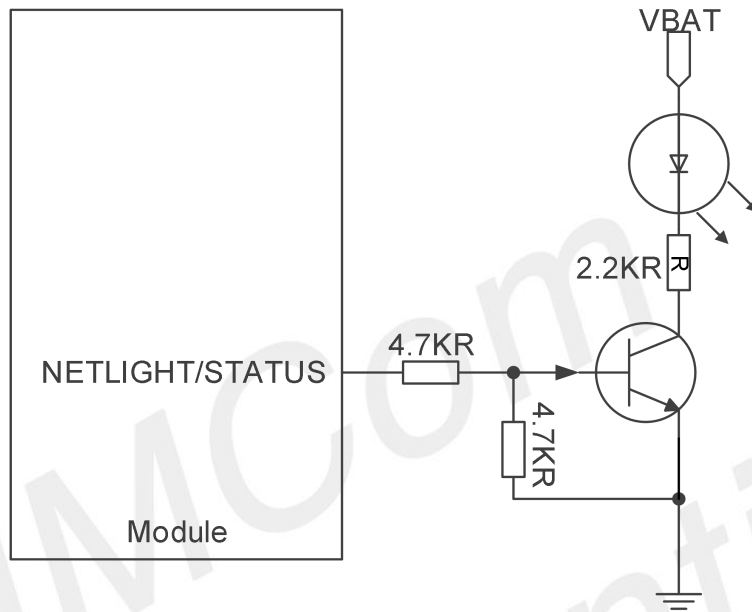

Figure 30: NETLIGHT/STATUS reference circuit

NOTE

1. The value of the resistor named “R” depends on the LED characteristic.

3.10 ADC Interface

A7681(A7665)E/SA/JP/NA, A7682E, A7683E, A7663E and SIM800C provide 1 ADC interface.

Table 9: ADC interface parameters

Function	A7681(A7665)E/SA/JP/NA	A7682E	A7683E	A7663E	SIM800C
ADC	12bits 0~1.2V	9bits 0~1.8V	12bits 0~1.2V	12bits 0~1.2V	10bits 0~2.8V

3.11 GNSS Interface

A7682E/A7683E/SIM800C do not support GNSS function. A7681E and A7663E has integrated GNSS function inside. Supports GPS, BeiDou, and GLONASS navigation systems. The GNSS functions are turned off by default, and the 'AT+CGNSSPWR=1' and 'AT+CGNSSTST=1' functions are called to open the GNSS function and obtain NMEA data. The GNSS serial port of A7663E has been connected to UART3. The customer only needs to complete the GNSS antenna part of the design, and the transparent transmission function has been done inside the module, and the customer can directly obtain the data directly from the NMEA port in the USB port.

3.12 RF Interface

3.12.1 Passive Antenna for LTE/GNSS

The reference circuit of the RF MAIN_ANT or GNSS passive antenna connection is shown in the figure below:

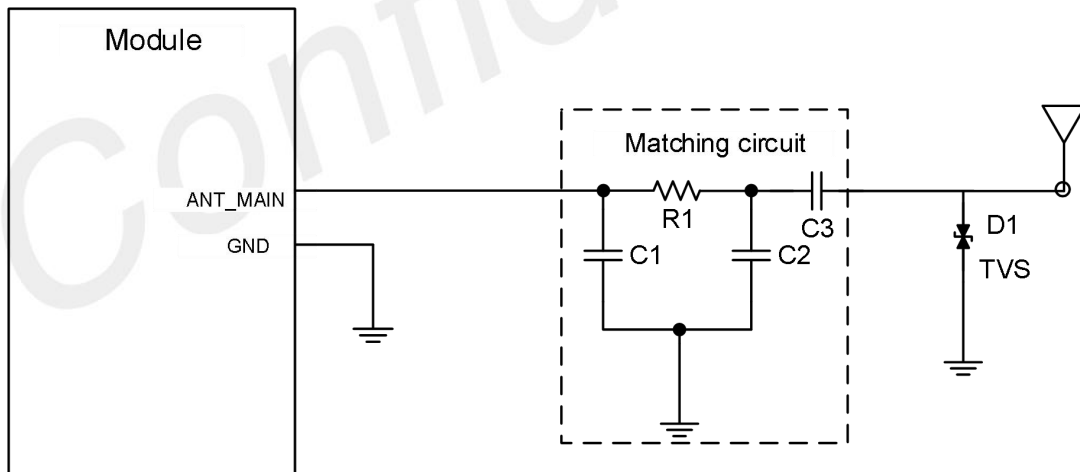

Figure 31: Antenna matching circuit

The component labeled as R1/C1/C2/C3 in the figure above serves as an antenna matching circuit. The values of these components can only be determined after tuning the antenna, a task typically undertaken by the antenna factory. Specifically, R1 should have a 0Ω value, C3 should be set at 100pF, while C1 and C2 are not initially populated.

The component denoted as D1 is a bidirectional ESD protection device, and it is advisable to include it in the protection circuit. The table below presents the recommended part numbers for TVS (Transient Voltage Suppression) devices intended for use with the RF main antenna:

Table 10: Recommended TVS

Manufacturer	Part Number	V_{RWM}	$V_C(Max)$	$C_J(Max)$	Package
BiLSEMI	BLE5V0CR05UB	5V	40V	0.05pF	DFN1006-2L

3.12.2 Active Antenna for GNSS

A7682E/A7683E/SIM800C do not support GNSS function, The GNSS active antenna reference circuit of A7681(A7665)E/SA/JP/NA、A7663E is shown below:

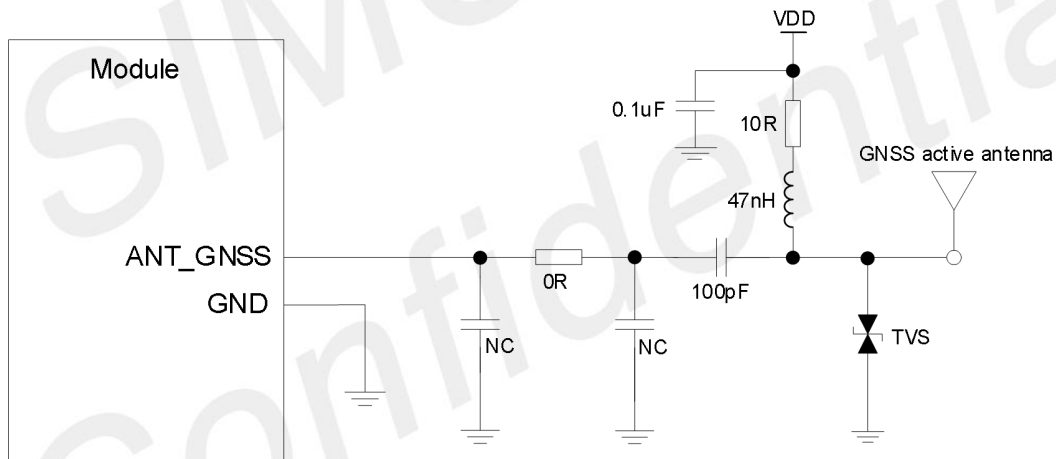

Figure 32: Antenna matching circuit

NOTE

- GNSS adopts the active antenna design scheme by default, and C uses 100pF by default. For customers using the passive antenna scheme, it is recommended to disconnect the power supply path to avoid chip damage caused by passive antenna installation.
- There may be parallel inductance at the antenna inside the module, showing a similar short circuit phenomenon, which is normal. Please consult SIMCom if you have any doubts about this.

3.12.3 Bluetooth Antenna Interface

SIM800C provides one Bluetooth antenna. It is recommended to reserve the matching circuit as follows:

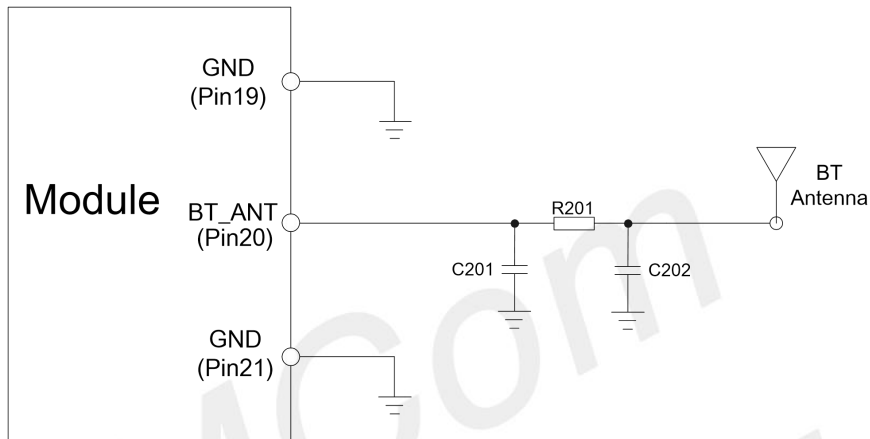

Figure 33: Bluetooth antenna matching circuit

R201, C201, C202 are the matching circuit, the value should be defined by the antenna design. Normally R201 is 0R, C202 and C201 are not mounted.

NOTE

The Bluetooth function of SIM800C requires custom software. Please consult SIMCom if you have any doubts about this.

4 Appendix

4.1 Related documents

Table 11: Related documents

SN	Document name	Remark
[1]	A7681E_Hardware_Design	A7681E_Hardware Design Manual
[2]	A7681JP_Hardware_Design	A7681JP_Hardware Design Manual
[3]	A7665SA_Hardware_Design	A7665SA_Hardware Design Manual
[4]	A7665NA_Hardware_Design	A7665NA_Hardware Design Manual
[2]	A7682E_Hardware Design	A7682E_Hardware Design Manual
[3]	A7683E_Hardware_Design	A7683E_Hardware Design Manual
[4]	A7663E_Hardware_Design	A7663E_Hardware Design Manual
[4]	SIM800C_Hardware_Design	SIM800C_Hardware Design Manual

4.2 Terms and Abbreviation

Table 12: Terms and Abbreviation

Abbreviation	Description
ESD	Electrostatic Discharge
GSM	Global Standard for Mobile Communications
I2C	Inter-Integrated Circuit
PCB	Printed Circuit Board
PCS	Personal Communication System, also referred to as GSM 1900
RF	Radio Frequency
RTC	Real Time Clock
RX	Receive Direction
SIM	Subscriber Identification Module

UART	Universal Asynchronous Receiver & Transmitter
NC	Not connect
EDGE	Enhanced data rates for GSM evolution
HSDPA	High Speed Downlink Packet Access HSUPA
USIM	Universal subscriber identity module
UMTS	Universal mobile telecommunications system
SMPS	Switch Mode Power Supply

SIMCom
Confidential