

RoHS

0.08 (01)

REV.	ECN.#	DESCRIPTION	NAME	DATE
A0		NEW RELEASE	TPY	2019.07.25
A1		外壳印字位置变更	HT	2019.08.14
A2		依实物变更尺寸	XHW	2021.04.14
A3		旧模老化, 重开新模	lhp.liu	2024.04.02

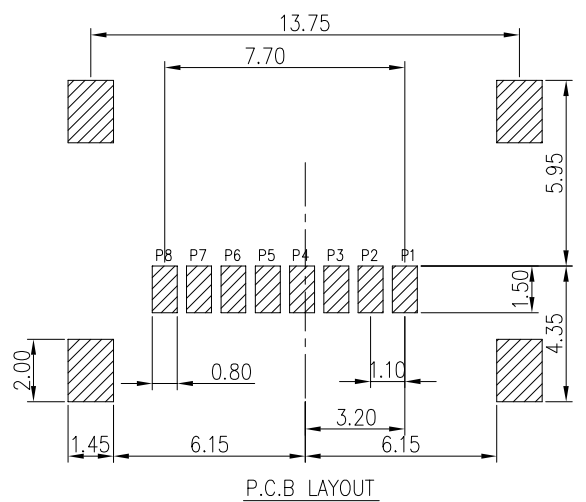
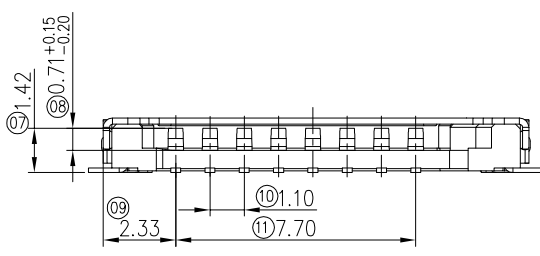
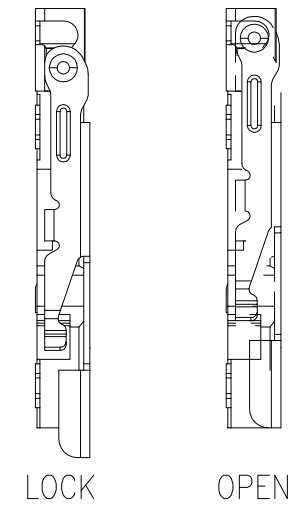
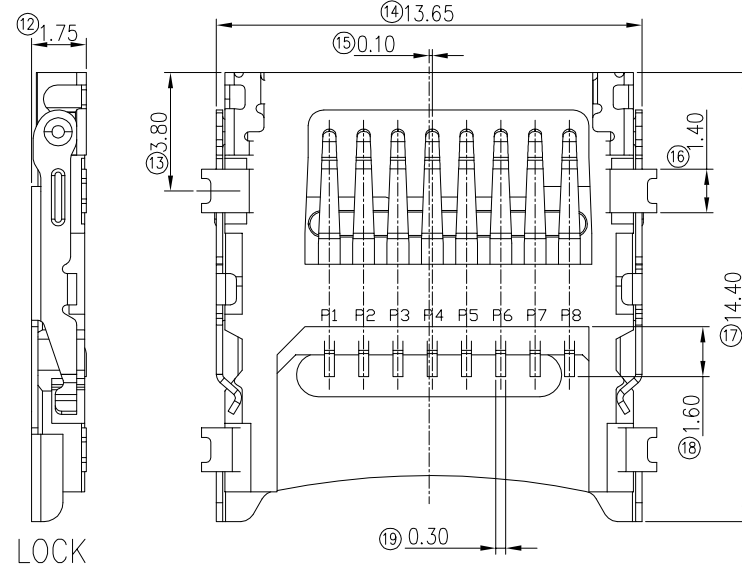
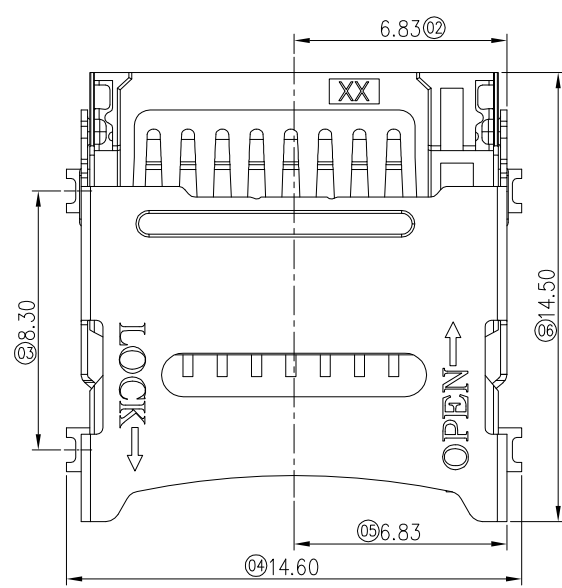

PART NO.	PLATING
404400241-A	G/F
404420241-A	3u"

- NOTES:
- MATERIAL:
 - HOUSING: LCP UL94V-0; COLOR: BLACK
 - TERMINAL: C2680
 - SHELL: SUS201
 - FINISH:
 - TERMINAL: G/F PLATED ON CONTACT AREA; Tin 80u", PLATED ON SOLDER AREA; Ni 30u" MIN. UNDERPLATED OVERALL.
 - SHELL: CLEANING
 - ELECTRICAL SPECIFICATION:
 - RATED CURRENT: 0.5A;
 - CONTACT RESISTANCE: 100mΩ MAX.
 - INSULATION RESISTANCE: 1000MΩ MIN AT 250V DC.
 - DIELECTRIC WITHSTANDING VOLTAGE: 500V AC.
 - MACHINERY SPECIFICATION:
 - MATING FORCE: 1N~10N. UNMATING FORCE: 1N~10N.
 - DURABILITY: 1500 CYCLES MIN.
 - ENVIRONMENTAL SPECIFICATION:
 - OPERATING CONDITION: TEMPERATURE -40°C~+85°C; HUMIDITY 80% R.H MAX
 - SALT SPRAY: 24H
 - SOLDER ABILITY: 245±5°C, 5±0.5s
 - IR REFLOW: THE PEAK TEMPERATURE ON THE BOARD SHALL BE MAINTAINED FOR 10 SECONDS AT 260°C.

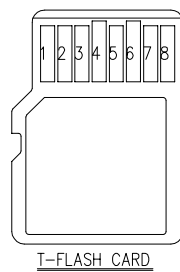

PIN NO.	PIN Assignmeng.
PIN1	DAT2
PIN2	CD/DAT3
PIN3	CMD
PIN4	VDD
PIN5	CLK
PIN6	Uss2
PIN7	DAT0
PIN8	DAT1

MILLIMETERS	INCH
X.* ±2*	X.* ±2*
X ±0.30	.X ±0.012
XX ±0.20	.XX ±0.008
XXX ±0.10	.XXX ±0.004

THESE DRAWINGS AND SPECIFICATIONS ARE THE PROPERTY OF DongGuan JinBilai Metal Plastic Technology Co.,Ltd
 COPIED OR USED IN ANY MANNER WITHOUT THE PRIOR WRITTEN CONSENT OF DongGuan JinBilai Metal Plastic Technology Co.,Ltd

JBL 东莞市金比莱五金塑胶科技有限公司
 DongGuan JinBilai Metal Plastic TechnologyCo.,Ltd

TITLE	T-FLASH 1.80H 掀盖式	DR	
PART NO.	404400241-A	CHKD	
PRO J.	PAGE 1/2	UNITS mm	APPD
SIZE	A4	SCALE 1:1	DIS NO.

RoHS

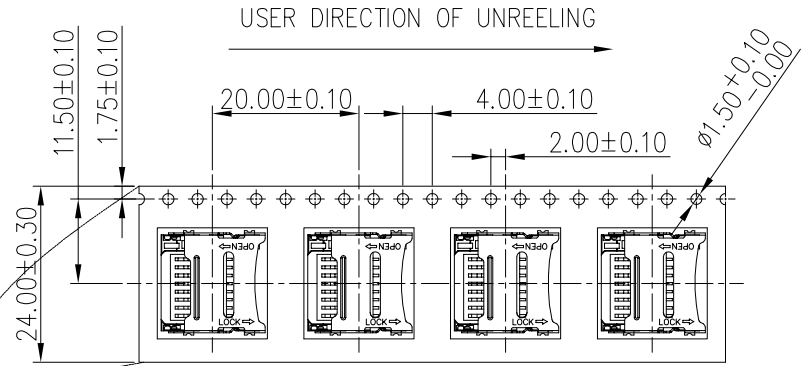

COVER TAPE PEELING ANGLE: 165°~180°
PEELING FORCE: 20~130g

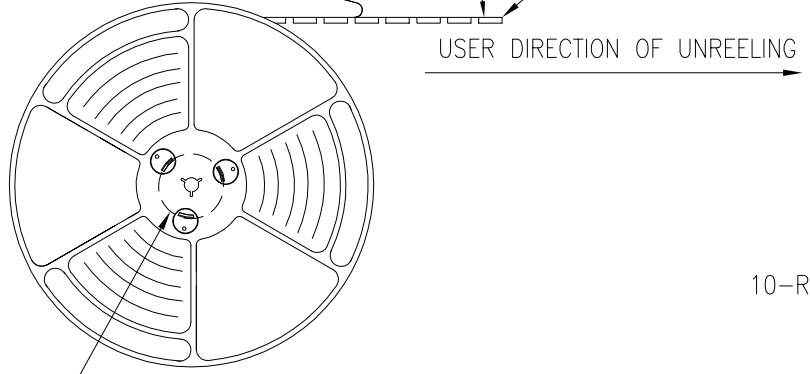

DETAIL B

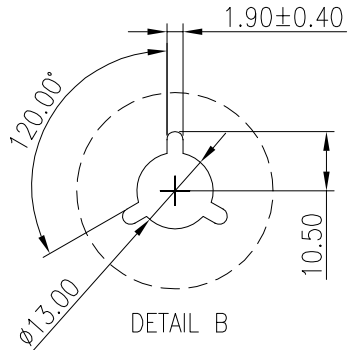

DETAIL B

NOTES

1. NUMBER OF CONNECTORS: 1200PCS/REEL
2. LEAD TAPE LENGTH

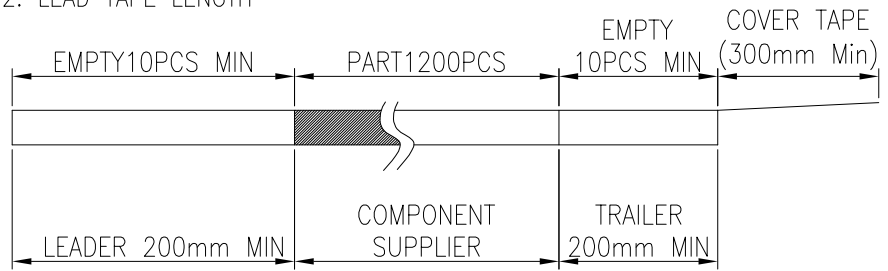

3. QUANTITY: 12000PCS/CARTON

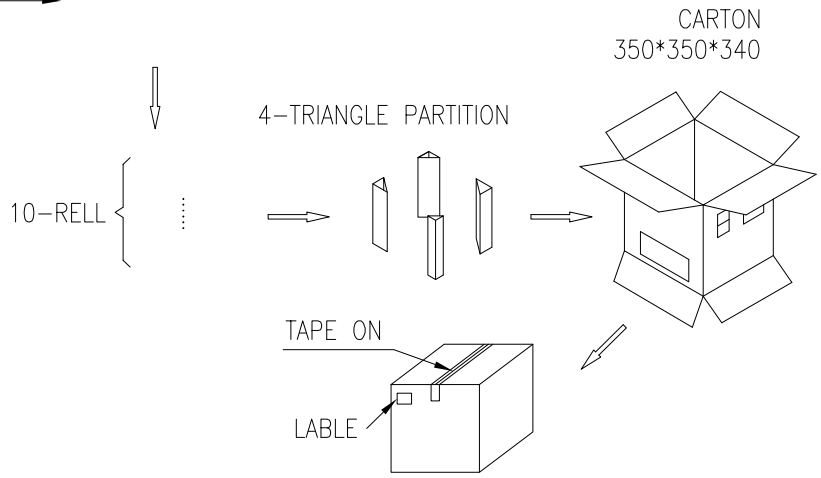

MILLIMETERS	INCH	东莞市金比莱五金塑胶科技有限公司 DongGuan JinBiLai Metal Plastic Technology Co.,Ltd				
X.* ±2*	X.* ±2*		TITLE	T-FLASH 1.80H 掀盖式	DR	
X ±0.30	.X ±0.012		PART NO.	404400241-A	CHKD	
XX ±0.20	.XX ±0.008		PRO J.	PAGE 2/2	UNITS mm	APPD
XXX ±0.10	.XXX ±0.004		SIZE	A4	SCALE 1:1	DIS NO.
<small>THESE DRAWINGS AND SPECIFICATIONS ARE THE PROPERTY OF DongGuan JinBiLai Metal Plastic Technology Co.,Ltd COPIED OR USED IN ANY MANNER WITHOUT THE PRIOR WRITTEN CONSENT OF DongGuan JinBiLai Metal Plastic Technology Co.,Ltd</small>						