

Date code: YWW  
 Y=Year, 0~9  
 WW=Week, 1~52  
 D=Day, 1~7

**SPECIFICATION:**

- 1. ELECTRICAL
  - 1.1 Current Rating: 0.5A per pin
  - 1.2 Voltage Rating: 50VAC
  - 1.3 Contact Resistance: 50mΩ
  - 1.4 Insulation Resistance: 500MΩ
  - 1.5 Dielectric Withstanding Voltage: 300VAC

- 2. MECHANICAL
  - 2.1 Durability: 60 Cycle
  - 2.2 Mating Force: 20N max.
  - 2.3 Un-mating Force: 25N max.

- 3. ENVIRONMENTAL
  - 3.1 Operating temperature range: -40°C~+85°C
  - 3.2 Storage temperature range: -40°C~+85°C

- 4. SOLDER ABILITY
  - 4.1 Recommended IR Reflow(Wave Soldering) Temperature: 260°C

4	HOLD DOWN	BRASS, C2680R-H, 100u" Matte Tin plated, under-plated Nickel 50u"
3	LOWER CONTACT	PHOSPHOR BRONZE, C5210R-EH
2	UPPER CONTACT	Contact area: Gold flash, Solder area: Gold flash, all under-plated Nickel 50u"
1	INSULATOR	LCP, UL94V-0, BLACK
NO.	PART NAME	DESCRIPTION

**RoHS Compliant** **HSM 玄茂科技股份有限公司**  
**HSUAN MAO TECHNOLOGY CO., LTD.**

APPD. 核准	SCALE 比例 参考	UNITS: DECIMAL LINEAR ANGLES	PART NAME 品名 0.5mm M.2 SOCKET CONNECTOR 67PIN SMT 90° H=4.0mm E KEY TYPE SELECTIVE GOLD PLATING BLACK INSULATOR REEL PACKING ROHS	
DWG. 製圖		mm		
DATE 制表日		UNIT 單位		SIZE 紙張尺寸
2020/03/02		M M		A 4
	PAGE 張數	REV. 版次	PART NO. 料號	
	1 OF 3	A	C3625-67BESBR1R	

Recommended Layout (Top View)  
 General Tolerance: ±0.05mm

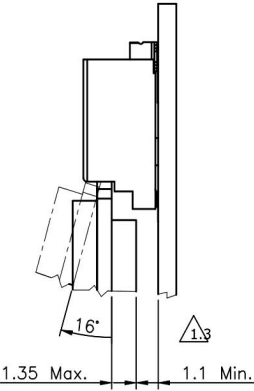

1 2 3 4 5 6 7 8

A

B

C

D

E

F

G

H

A

B

C

D

E

F

G

H

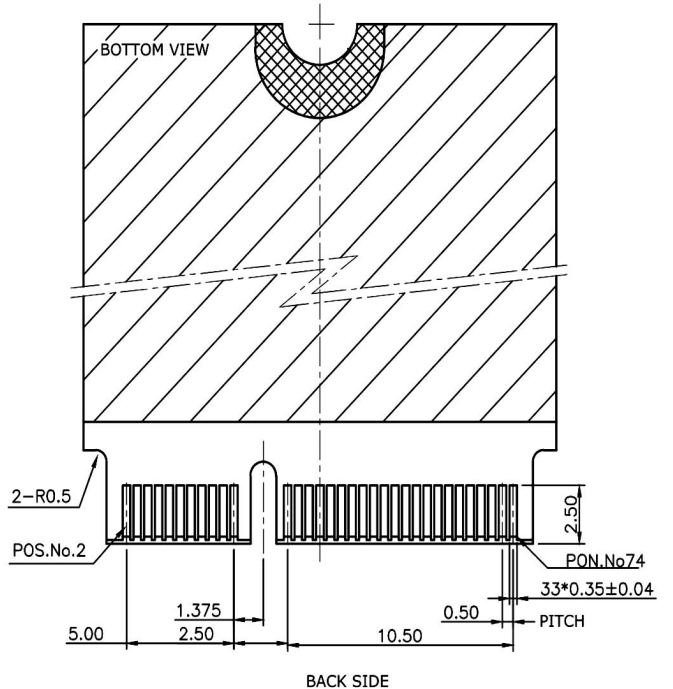
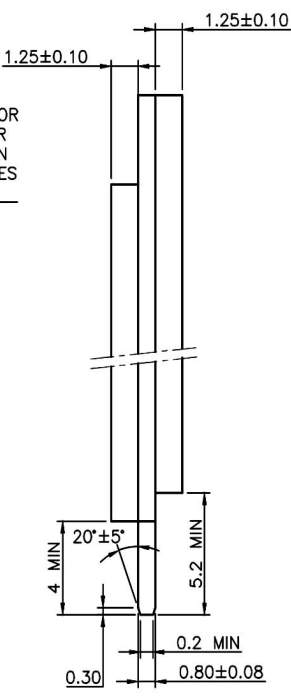
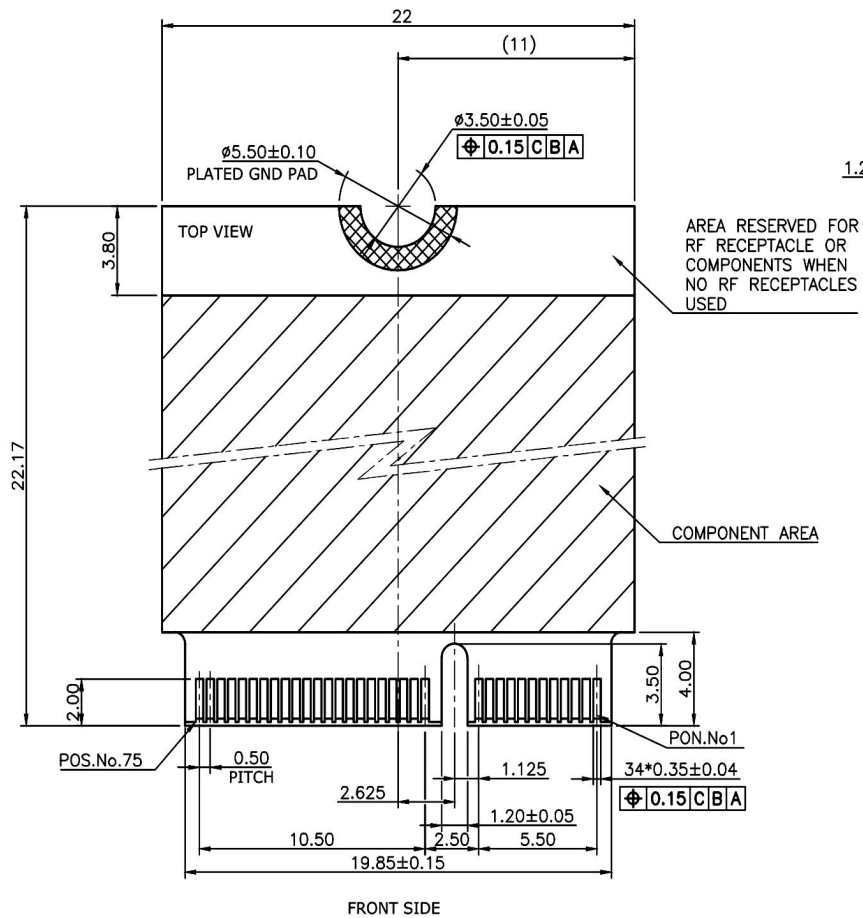

KEY ID "E"  
RECOMMENDED MODULE LAYOUT

RoHS Compliant		HSM 玄茂科技股份有限公司 HSUAN MAO TECHNOLOGY CO., LTD.	
APPD. 核准	SCALE 比例 参考	TOLERANCE 容許公差	PART NAME 品名
DWG. 製圖 Betty		.0 ± 0.30 .00 ± 0.20 ANG. ± 3°	0.5mm M.2 SOCKET CONNECTOR 67PIN SMT 90° H=4.0mm E KEY TYPE SELECTIVE GOLD PLATING BLACK INSULATOR REEL PACKING ROHS
DATE 制表日	UNIT 單位 M M	SIZE 紙張尺寸 A 4	PART NO.
2020/03/02	PAGE 張數 2 OF 3	REV. 版次 A	料號 C3625-67BESBR1R

1 2 3 4 5 6 7 8

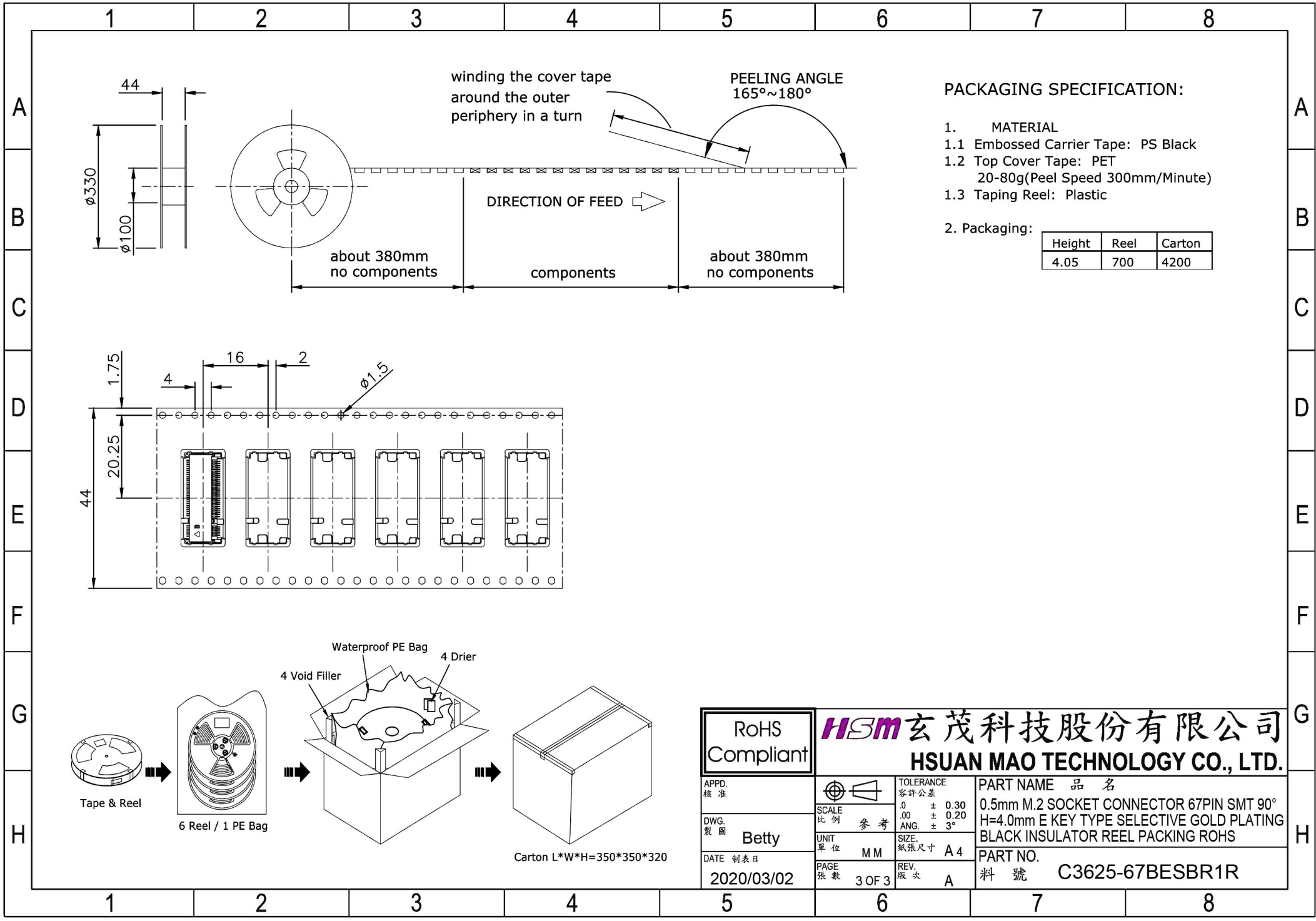

**PACKAGING SPECIFICATION:**

- 1. MATERIAL
  - 1.1 Embossed Carrier Tape: PS Black
  - 1.2 Top Cover Tape: PET 20-80g(Peel Speed 300mm/Minute)
  - 1.3 Taping Reel: Plastic

2. Packaging:

Height	Reel	Carton
4.05	700	4200

RoHS Compliant

**HSM** 玄茂科技股份有限公司  
**HSUAN MAO TECHNOLOGY CO., LTD.**

APPD. 核准  
 DWG. 製圖 Betty  
 DATE 制表日 2020/03/02

SCALE 比例 參考  
 UNIT 單位 MM  
 PAGE 張數 3 OF 3

TOLERANCE 容許公差  
 .0 ± 0.30  
 .00 ± 0.20  
 ANG. ± 3°  
 SIZE. 紙張尺寸 A 4  
 REV. 版次 A

PART NAME 品名  
 0.5mm M.2 SOCKET CONNECTOR 67PIN SMT 90°  
 H=4.0mm E KEY TYPE SELECTIVE GOLD PLATING  
 BLACK INSULATOR REEL PACKING ROHS

PART NO.  
 料號 C3625-67BESBR1R