

**Bluetooth Low Energy (BLE)  
Data Transmission Module**

**BMT2604RP  
User Guide**

Version	Date	Modification
v1.0	2025.8.14	Initial version

## Table of Contents

1	Product Overview .....	4
2	Module Features .....	4
3	Module Function Description .....	5
4	Application Diagram .....	5
5	Module Pin .....	7
6	Data Transmission Protocol.....	8
7	ATCommand.....	9
7.1	TTM:CIT-Xms .....	9
7.2	TTM:NAM-? .....	9
7.3	TTM:REN-x .....	9
7.4	TTM:BPS-? .....	10
7.5	TTM:BPS-x.....	10
7.6	TTM:MAC-?.....	10
7.7	TTM:MAC-x.....	11
7.8	TTM:PHY-x .....	11
7.9	TTM:ADP-(x) .....	12
7.10	TTM:ADVPHY-x .....	13
7.11	TTM:SPC-x.....	13
7.12	TTM:RSI-x.....	14
7.13	TTM:ICVOLTAGE-? .....	14
7.14	TTM:ADD-x .....	14
7.15	TTM:PID-x.....	15
7.16	TTM:SERUUID-x.....	15
7.17	TTM:RXUUID-x.....	16
7.18	TTM:TXUUID-x.....	16
7.19	TTM:CDL-Xms .....	16
7.21	TTM:SMT-x.....	18
7.22	TTM:RST-SYSTEM RESET.....	18
7.23	TTM:REV-? .....	19
7.24	TTM:RESET PARAMETER-0.....	19
8	BLE Services .....	20
8.1	Data transmission Service 【UUID: 0xFFE0】 .....	20
8.2	Authentication Configuration Service 【UUID: 0xFFC0】 .....	20
8.3	Module parameter configuration service 【UUID: 0xFF90】 .....	22
8.4	Device Information Service 【UUID: 0x180A】 .....	24
9	Other Return status .....	24
10	Contact Information.....	25

## 1 Product Overview

BMT2604RP is a BLE data transmission module, based on the CMT4531 low-power BLE 5.2 chip. The module communicates with an external MCU via UART to quickly set up wireless connection and data transfer between BLE peripheral devices and BLE central devices (such as mobile phones and tablets). The external MCU has a low resource occupation and makes it easy for the developer to solve complex wireless communication challenges and accelerate time to market.

## 2 Module Features

- Easy to use without any experience in Bluetooth stack application;
- Can be used as a BLE data transmission module or as a BLE SoC for user application development;
- Support universal serial interface UART communication with the host MCU, the baud rate can be 9600bps to 500000bps;
- Support LE 1M/2M /500K/125K PHY and LE Coded PHY, and the MTU is configurable;
- Support AT commands to adjust the transmit power, modify the advertising interval, customize the advertising data, customize the device identification code, set the data delay (the preparation time for external host MCU to receive data from serial port), modify the baud rate of serial port, modify the module name, and support data preservation when power is off;
- Support AT command to reset module, get MAC address;
- UART buffer can receive no more than 2K byte data at one time from the host MCU;
- Support Bluetooth security feature and application layer authentication to prevent MITM (man-in-the-middle) attacks;

### 3 Module Function Description

After the module is powered on, it is recommended to wait for 110MS or until the module serial port outputs "TTM: SYSTEM-RST" before starting any operation. If the PDN (BLE function control pin) and WAKEUP (wake-up control pin) are not pulled down after powering on, the module will be in sleep mode, and the power consumption will be around 1.4uA.

Pull down the WAKEUP pin and keep it low, the Bluetooth module will remain in the wake-up state and not enter sleep mode. At this time, the host MCU can issue AT commands through the serial port to configure the module's parameters or transfer data to the central device side. While the BLE module receives any data from the central device, it will forward them to the serial port no matter the state of the WAKEUP pin. It is recommended to pull WAKEUP low for at least 3MS before sending any data to the serial port, and wait for at least 3MS before pulling up WAKEUP pin after finishing data transmission. At any time, if pull up the WAKEUP pin, the module will no longer maintain the wake-up state and will enter the sleep state when there is no event to process.

In addition, the INT pin is a notification pin, which is used to notify the host MCU that the BLE module has received some data, this pin can be used to wake up the host MCU for data processing. When the serial port has data to be sent to the host MCU, the INT pin will be pulled low for N ms (the delay is configurable, please refer to section [错误!未找到引用源。](#) for the AT command) and start sending data then. After the data sending is completed, the INT pin will be pulled up.

### 4 Application Diagram

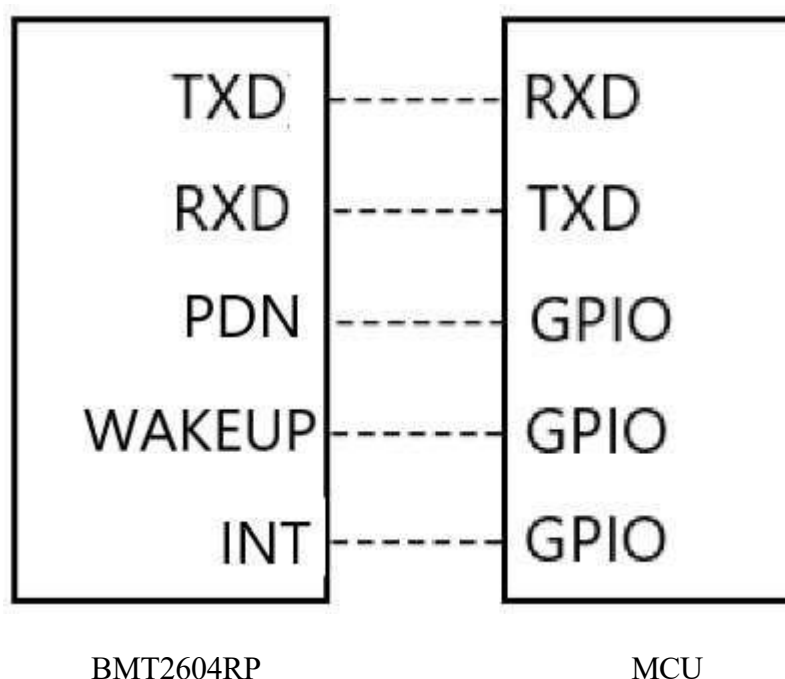

In general, there are five pins connected between the BLE module and the host MCU: TXD, RXD, PDN, WAKEUP, and INT. The TXD and RXD are data transmit and receive pins of the serial port. PDN is used to start the BLE functionality. The WAKEUP pin, which is active low, is used to keep the BLE module in the wake-up state and keep the serial port in the working state. The INT pin will output low to notify the host MCU while the BLE module serial port has some data to be sent.

If there is no need to reduce power consumption, both the WAKEUP and PDN pins can be pulled down directly. If the host MCU has limited IO resources, and there is no need for the INT pin notification, it can be left floating.

## 5 Module Pin

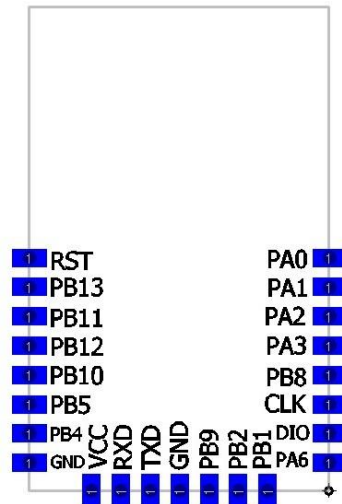

Module Pinout (Bottom View)

### Module Pin Definition (Complete pinout refer to the module datasheet)

Pin Name	Type	Description
CLK	I/O	SWDCLK/TIM1_CH3N/USART1_TXD/KEY9/PA4
DIO	I/O	SWDIO/TIM1_ETR/USART1_RXD/KEY10/PA5
GND	DG	Digital Ground
TXD	O	BLE UART transmission TXD/PB6 (Note1)
RXD	I	BLE UART unvarnished transmission RXD/PB7
VCC	AP,DP	Power Supply:1.8V~3.6V
WAKEUP	I	Wakeup Pin, Low level effective/PB4
PDN	I	BLE functionality, Low level effective/PB5
INT	O	UART Tx Signal/PB11

Module Pin Definition

Note:

1. Module UART TX (PB6) may experience a brief low level during the reset process or when reconfiguring the serial port from sleep to wake-up, which may cause the other master control RX to receive garbled data. If there is any impact, it is recommended to add an external pull-up at the TX port during the design.

## 6 Data Transmission Protocol

The BLE module is connected to the host MCU through the UART serial port, and the host MCU can establish wireless communication with the mobile device or other BLE module. Users can configure the baud rate of the serial port, BLE connection interval, and other parameters with AT commands (see AT Command for more information).

For different serial port baud rates, BLE connection intervals, and different packet sending intervals, the module will have different data throughput. The baud rate of the serial port is 115200bps 8N1 by default. The UART buffer can receive up to 3K byte data at one time from the host MCU data, and it will segment and assemble the data automatically with the MTU setting. The data sent from the central device to the BLE module must be written to the right service and characteristic. After receiving any data from the central device, the BLE module will pull low the INT pin and output the data from the UART Tx pin then.

A string starting with "TTM:" and ending with "\r\n\0" will be parsed and executed as an AT command, and return the result ("TTM:OK\r\n\0" or "TTM: ERP\r\n\0", etc.). Any data packets that do not comply with AT command rules will be treated as raw data and transmitted to the central device.

Note that the "\r\n\0" at the end of the command will not be repeated when introducing the command below.

There are two types of command, control command and query command. Host MCU can control the BLE module with the control command for configuring the parameters such as module name, connection interval, advertising interval, UART baud rate, etc. With the query command, the host MCU can retrieve the information from the module such as module

name, MAC address, baud rate, etc.

## 7 AT Command

### 7.1 TTM:CIT-Xms

Request a change in the connection interval.

Command	Syntax	Return status	Result code
Control cmd	TTM:CIT-Xms	TTM:OK TTM:ERP	Success Invalid parameter
Parameters	1. x is the required connection interval, unit is MS。 2. The range of the connection interval is 20-2000 and should be multiple of 10.		
Note	1. The setting will be saved to non-volatile flash memory and loaded automatically on reboot 2. It's recommended to set the preferred connection interval before the connection established 3. While the connection interval is less than 30MS, modifying any parameters that will be saved to non-volatile flash may cause the Bluetooth connection to be disconnected. 4. The peripheral device will request a change in connection interval with the default value 100-200MS.		
Example	TTM:CIT-100ms TTM:OK		

### 7.2 TTM:NAM-?

Get the module name.

Command	Syntax	Return status	Result code
Query cmd	TTM:NAM-?	TTM:NAM-x	x is the module name.
Parameters	None		
Note	None		
Example	TTM:NAM-? TTM:NAM-CMT4531-33445566		

### 7.3 TTM:REN-x

Modify the name of the module.

Command	Syntax	Return status	Result code
---------	--------	---------------	-------------

Control cmd	TTM:REN-x	TTM:OK TTM:ERP	Success Invalid parameter
Parameters	1. x is the name of the Bluetooth module to be set, with a length of 1-20 bytes.		
Note	1. The setting will be saved to non-volatile flash memory and loaded automatically on reboot 2. The default name is CMT4531-<last 4 bytes of the MAC address>. For example, the device MAC address is 112233445566, default name will be CMT4531-33445566.		
Example	TTM:REN-HopeRf TTM:OK		

## 7.4 TTM:BPS-?

Query the baud rate of the serial port.

Command	Syntax	Return status	Result code
Query cmd	TTM:BPS-?	x	x is the baud rate
Parameters	None		
Note	None		
Example	TTM:BPS-? 115200		

## 7.5 TTM:BPS-x

Configure the baud rate of the serial port.

Command	Syntax	Return status	Result code
Control cmd	TTM:BPS-x	TTM:OK TTM:ERP	Success Invalid parameter
Parameters	1. x: baud rate setting. 2. The available baud rate are: 9600, 19200, 38400, 57600, 115200, 250000, 500000.		
Note	1. The setting will be saved to non-volatile flash memory and loaded automatically on reboot 2. The default baud rate is 115200bps.		
Example	TTM:BPS-115200 TTM:OK		

## 7.6 TTM:MAC-?

Get the MAC address of the Bluetooth module.

Command	Syntax	Return status	Result code
Query cmd	TTM:MAC-?	TTM:MAC-x	x is the MAC address
Parameters	None		
Note	None		
Example	TTM:MAC-? TTM:MAC-112233445566		

## 7.7 TTM:MAC-x

Set the MAC address of the Bluetooth module.

Command	Syntax	Return status	Result code
Control cmd	TTM:MAC-x	TTM:OK TTM:ERP	Success Invalid parameter
Parameters	1. x is the MAC address to be set		
Note	1. The setting will be saved to non-volatile flash memory and loaded automatically on reboot 2. After setting the MAC address successfully, the Bluetooth module will be reset automatically for taking effect.		
Example	TTM:MAC-112233445566 TTM:OK		

## 7.8 TTM:PHY-x

Set preferred and accepted PHYs.

Command	Syntax	Return status	Result code
Control cmd	TTM:PHY-x	TTM:OK TTM:ERP	Success Invalid parameter
Parameters	1. x is the index of the PHY: "0":1Mbps "1":2Mbps "2":500Kbps "3":125Kbps "4":All PHYs		
Note	1. The setting will be saved to non-volatile flash memory and loaded automatically on reboot 2. By default, it supports All PHYs (x=4).		
Example	TTM:PHY-0 TTM:OK		

---

## 7.9 TTM:ADP-(x)

Set the advertising interval.

Command	Syntax	Return status	Result code
Control cmd	TTM:ADP-(x)	TTM:OK TTM:ERP	Success Invalid parameter
Parameters	1. x is the advertising interval to be set 2. advertising interval=x*100ms, and the x can be 1-50 (100 - 5000ms).		
Note	1. The setting will be saved to non-volatile flash memory and loaded automatically on reboot 2. The default advertising interval is 200MS。		
Example	TTM:ADP-(1) TTM:OK		

## 7.10 TTM:ADVPHY-x

Set the advertising PHYs.

Command	Syntax	Return status	Result code
Control cmd	TTM:ADVPHY-x	TTM:OK TTM:ERP	Success Invalid parameter
Parameters	1. x is the index of the advertising PHY. 0 indicates 1M PHY, 1 indicates 125K PHY.		
Note	1. The setting will be saved to non-volatile flash memory and loaded automatically on reboot 2. The default advertising PHY is 1M PHY.		
Example	TTM:ADVPHY-0 TTM:OK		

## 7.11 TTM:SPC-x

Set the passkey of the peripheral device for Bluetooth pairing and bonding security feature support.

Command	Syntax	Return status	Result code
Control cmd	TTM:SPC-x	TTM:OK TTM:ERP	Success Invalid parameter
Parameters	1. x can be the value below “OFF”: disable the security feature “DEL”: delete the bonding table “xxxxxx”: Passkey, valid range: 000000-999999.		
Note	1. The setting will be saved to non-volatile flash memory and loaded automatically on reboot. 2. The security feature is disabled by default. 3. A reset is needed for taking effect. 4. Once the feature is enabled, the central device can only operate the characteristic of the peripheral device after pairing successfully. 5. It can support up to 5 bonds saved in the peripheral’s bonding table, if the bonding table is full, the oldest one will be deleted.		
Example	TTM:SPC-123456 TTM:OK		

## 7.12 TTM:RSI-x

Enable or disable the RSSI display for the current connection.

Command	Syntax	Return status	Result code
Control cmd	TTM:RSI-x	TTM:OK TTM:ERP	Success Invalid parameter
Parameters	1. x can be ON or OFF, once this feature is enabled, the Bluetooth module will output the RSSI periodically with 1s interval.		
Note	1. The command will only take effect if Bluetooth connection is established.		
Example	TTM:RSI-ON TTM:RSI--63		

## 7.13 TTM:ICVOLTAGE-?

Monitor the voltage of the battery.

Command	Syntax	Return status	Result code
Query cmd	TTM:ICVOLTAGE-? ?	TTM:ICVOLTAGE-x	Battery voltage
Parameters	1. x is the battery voltage (Unit: MV)		
Note	None		
Example	TTM:ICVOLTAGE-? TTM:ICVOLTAGE-3305		

## 7.14 TTM:ADD-x

Set user-defined data in advertising packets.

Command	Syntax	Return status	Result code
Control cmd	TTM:ADD-x	TTM:OK TTM:ERP	Success Invalid parameter
Parameters	1. x is the user-defined data to be set in the advertising packets, the length can be 1-16 byte.		
Note	1. The setting will be saved to non-volatile flash memory and loaded automatically on reboot 2. The user-defined data will be in the “Manufacturer Specific Data” element of the advertisement with AD type 0xFF.		
Example	TTM:ADD-HopeRf TTM:OK		

## 7.15 TTM:PID-x

Change the product PID.

Command	Syntax	Return status	Result code
Control cmd	TTM:PID-x	TTM:OK TTM:ERP	Success Invalid parameter
Parameters	1. x is a 2 bytes product ID, each character should be entered in ASCII format.		
Note	1. The setting will be saved to non-volatile flash memory and loaded automatically on reboot 2. The 2 bytes PID will be in the “Manufacturer Specific Data” element of the advertisement with AD type 0xFF.		
Example	TTM:PID-RS TTM:OK		

## 7.16 TTM:SERUUID-x

Set the data transmission service UUID.

Command	Syntax	Return status	Result code
Control cmd	TTM:SERUUID-x	TTM:OK TTM:ERP	Success Invalid parameter
Parameters	1. x is the 2 bytes or 16 bytes service UUID		
Note	1. The setting will be saved to non-volatile flash memory and loaded automatically on reboot 2. The default data transmission service UUID is FFE0. 3. This setting will take effect after reset.		
Example	TTM:SERUUID-7788 TTM:OK		

## 7.17 TTM:RXUUID-x

Set the data transmission RX characteristic UUID.

Command	Syntax	Return status	Result code
Control cmd	TTM:RXUUID-x	TTM:OK TTM:ERP	Success Invalid parameter
Parameters	1. x is the 2 bytes or 16 bytes characteristic UUID		
Note	<ol style="list-style-type: none"> <li>1. The setting will be saved to non-volatile flash memory and loaded automatically on reboot</li> <li>2. The default data transmission RX characteristic UUID is FFE9.</li> <li>3. The length of the data transmission service UUID and RX characteristic UUID should be the same. Otherwise, it will use the default UUID.</li> <li>4. This setting will take effect after reset.</li> </ol>		
Example	TTM:RXUUID-7788 TTM:OK		

## 7.18 TTM:TXUUID-x

Set the data transmission TX characteristic UUID.

Command	Syntax	Return status	Result code
Control cmd	TTM:TXUUID-x	TTM:OK TTM:ERP	Success Invalid parameter
Parameters	1. x is the 2 bytes or 16 bytes characteristic UUID		
Note	<ol style="list-style-type: none"> <li>1. The setting will be saved to non-volatile flash memory and loaded automatically on reboot</li> <li>2. The default data transmission TX characteristic UUID is FFE4.</li> <li>3. The length of the data transmission service UUID and TX characteristic UUID should be the same. Otherwise, it will use the default UUID.</li> <li>4. This setting will take effect after reset.</li> </ol>		
Example	TTM:TXUUID-7788 TTM:OK		

## 7.19 TTM:CDL-Xms

Set the INT delay.

Command	Syntax	Return status	Result code
Control cmd	TTM:CDL-Xms	TTM:OK TTM:ERP	Success Invalid parameter
Parameters	1. x is the desired delay before forwarding the data to the Host MCU (0-30ms).		
Note	1. The setting will be saved to non-volatile flash memory and loaded automatically on reboot 2. In order to ensure the Host MCU has enough time to wake up from sleep and receive serial port data reliably. The module provides the setting of this delay (x)ms. The INT pin will be pulled down before sending data out from the Bluetooth module's serial port. The actual delay will have a slight difference. 3. Default value is x=1。		
Example	TTM:CDL-1ms TTM:OK		

## 7.20 TTM:TPL-x

Set the global radiated TX power level for Bluetooth.

Command	Syntax	Return status	Result code
Control cmd	TTM:TPL-x	TTM:OK TTM:ERP	Success Invalid parameter
Parameters	1. x is the index of the TX power level "0":0dbm "1":-2dbm "2":-4dbm "3":-8dbm "4":-15dbm "5":-20dbm "6":2dbm "7":3dbm "8":4dbm "9":6dbm		
Note	1. The setting will be saved to non-volatile flash memory and loaded automatically on reboot 2. Default value is x=0(0dbm)。		
Example	TTM:TPL-0 TTM:OK		

## 7.21 TTM:SMT-x

Reset the system

Command	Syntax	Return status	Result code
Control cmd	TTM:RST-SYSTEMRESET	TTM:OK TTM:ERP	Success Invalid parameter
Parameters	1.x is the module type index: “0”:HM-BT4531 “1”:HM-BT4531B “2”:HM-BT4531C “3”:HM-BT4531MS		
Note	1.This parameter will be saved when power is off. 2.When the set module type is inconsistent with the current module, it will be cleared all user data and perform a soft reset.		
Example	TTM:SMT-0 TTM:OK		

## 7.22 TTM:RST-SYSTEM RESET

Command	Syntax	Return status	Result code
Control cmd	TTM:CDL-Xms	TTM:OK TTM:ERP	Success Invalid parameter
Parameters	2. x is the desired delay before forwarding the data to the Host MCU (0-30ms).		
Note	4. The setting will be saved to non-volatile flash memory and loaded automatically on reboot 5. In order to ensure the Host MCU has enough time to wake up from sleep and receive serial port data reliably. The module provides the setting of this delay (x)ms. The INT pin will be pulled down before sending data out from the Bluetooth module's serial port. The actual delay will have a slight difference. 6. Default value is x=1。		
Example	TTM:CDL-1ms TTM:OK		

### 7.23 TTM:REV-?

Get the firmware version of the Bluetooth module.

Command	Syntax	Return status	Result code
Control cmd	TTM:REV-?	TTM:REV-CMT4531-Vx.x	Firmware version
Parameters	None		
Note	None		
Example	TTM:REV-? TTM:REV-CMT4531-V1.0		

### 7.24 TTM:RESET PARAMETER-0

Restore factory settings

Command	Syntax	Return status	Result code
Control cmd	TTM:RESETPARAMETER-0	TTM:OK TTM:ERP	Success Invalid parameter
Parameters	None		
Note	1. Performs a factory reset that will erase all of the user configuration, the module will be reset to the default status, and a system reset process will be followed.		
Example	TTM:RESETPARAMETER-0 TTM:OK		

## 8 BLE Services

### 8.1 Data transmission Service 【UUID: 0xFFE0】

Characteristic UUID	Operations	Length	Note
FFE9	WRITE	Same as MTU	The data written in the characteristic will be output from the module's serial port Tx pin.
FFE4	NOTIFY	Same as MTU	The data inputted from the module's serial port Rx pin will be sent to the central device with notification.

The data written by the central device through the “FFE9” characteristic will be output to the module serial port Tx pin. While the notification procedure of the “FFE4” characteristic has been enabled, all of the data inputted from the module's serial port Rx pin will be sent to the central device with notification.

### 8.2 Authentication Configuration Service 【UUID: 0xFFC0】

The Bluetooth module supports the application layer authentication feature with further protection, and only the authorized remote central device can operate the characteristic. The initial password of the Bluetooth module is 000000 (ASCII) which means the authentication feature is disabled, and any central device can establish a Bluetooth connection to the module.

If any other new password (not all 0s) is set, the Bluetooth application layer authentication feature is enabled, the central device should enter the password within 20s after the connection is established, otherwise, the connection will be terminated by the peripheral device. The central device cannot do any operation except enter the password. A factory reset is needed for resetting the password.

The module provides characteristic for entering, modifying, and canceling the application layer authentication password, and another characteristic for notifying the status corresponding, including four status: correct password, incorrect password, successful password modification, and cancellation of password.

Characteristic UUID	Operations	Length	Example	Note
FFC1	WRITE	12	123456123456	Submit the password 123456, the new password must be same as the current password.
			123456888888	Change the password from the 123456 to 888888, and the current password must be correct.
			888888000000	Cancel the password, the new password should be 000000, and the current password must be correct.
FFC2	NOTIFY	1	0	The password is correct.
			1	The password is incorrect.
			2	Change the password successfully.
			3	Cancelled the password.

**Note:**

1. The password payload is a 12-byte ASCII code. The first 6 digits in red are the current password, and the last 6 digits in black are the new password.
2. The default password is "000000".
3. While the notification of the FFC2 characteristic is enabled, the result of the password related operation will be notified then.
4. While the central device submits the password "123456123456", the new password is the same as the current password, the central device will be notified "0" on the FFC2 characteristic, indicating that the password is correct.
5. While the central device submits the password (in red) is different with the current password, such as: "123455xxxxxx", no matter what the value of the x part is, the central device will be notified "1" on the FFC2 characteristic, indicating that the password is incorrect.
6. While the central device submits the password "123456888888", the new password is "888888", and the current password is "123456", the central device will be notified "2" on the FFC2 characteristic, indicating that the password has been changed successfully.

7. While the central device submits the password "888888000000" and the new password is changed to all 0s, it means that the password is cancelled, and the central device will be notified "3" on the FFC2 characteristic.

## 8.3 Module parameter configuration service 【UUID: 0xFF90】

### 8.3.1 Module name configuration

Characteristic UUID	Operations	Length	Persistence across power off
FF91	Read/write	1-20	Yes
Default	The default name is CMT4531-<last 4 bytes of the MAC address>. For example, the device MAC address is 112233445566, default name will be CMT4531-33445566.		
Note	None		

### 8.3.2 Connection interval

Characteristic UUID	Operations	Length	Persistence across power off
FF92	Read/write	2	Yes
Default	The peripheral device will request a change in connection interval with the default value 100-200MS.		
Note	<ol style="list-style-type: none"> <li>1. The range of the connection interval is 20-2000 and should be multiple of 10.</li> <li>2. While the connection interval is less than 30MS, modifying any parameters that will be saved to non-volatile flash may cause the Bluetooth connection to be disconnected.</li> <li>3. It's recommended to set the preferred connection interval before the connection established</li> <li>4. The peripheral device will request a change in connection interval with the default value 100-200MS.</li> <li>5. The value read from the characteristic should be multiplied by 1.25 to obtain the real connection interval. For example, read 160 indicates <math>160 * 1.25 = 200ms</math> connection interval.</li> </ol>		

### 8.3.3 Baud rate of the serial port

Characteristic UUID	Operations	Length	Persistence across power off
FF93	Read/write	4	Yes
Default	115200bps 8N1。		
Note	The available baud rate are: 9600, 19200, 38400, 57600, 115200, 250000, 500000.		

### 8.3.4 Reset the system and factory reset

Characteristic UUID	Operations	Length	Persistence across power off
FF94	write	1	No
Default	None		
Note	<ol style="list-style-type: none"> <li>1. Write 0x55、0x35 to reset the Bluetooth module.</li> <li>2. Write 0x36 to factory reset the Bluetooth module.</li> </ol>		

### 8.3.5 Advertising interval

Characteristic UUID	Operations	Length	Persistence across power off
FF95	Read/write	1	Yes
Default	The default advertising interval is 200MS.		
Note	<ol style="list-style-type: none"> <li>1. advertising interval=<math>x \times 100\text{ms}</math>, and the x can be 1-50 (100 - 5000ms).</li> <li>2. The value read from the characteristic should be multiplied by 0.625 to obtain the real advertising interval. For example, read 320 indicates <math>320 \times 1.25 = 200\text{ms}</math> advertising interval.</li> </ol>		

### 8.3.6 Product ID

Characteristic UUID	Operations	Length	Persistence across power off
FF96	Read/write	2	Yes
Default	00 00		
Note	The 2 bytes PID will be in the “Manufacturer Specific Data” element of the advertisement with AD type 0xFF.		

### 8.3.7 TX power level

Characteristic UUID	Operations	Length	Persistence across power off
FF97	Read/write	1	Yes

Default	0
Note	Index of the TX power level “0”:0dbm “1”:-2dbm “2”:-4dbm “3”:-8dbm “4”:-15dbm “5”:-20dbm “6”:2dbm “7”:3dbm “8”:4dbm “9”:6dbm

### 8.3.8 User-defined data in advertising packets

Characteristic UUID	Operations	Length	Persistence across power off
FF98	Read/write	1-16	Yes
Default	00		
Note	The user-defined data will be in the “Manufacturer Specific Data” element of the advertisement with AD type 0xFF.		

### 8.4 Device Information Service 【UUID: 0x180A】

Characteristic UUID	Operations	Note
2A28	read	Read the module firmware version: “CMT4531-V <sub>x.x</sub> ”

## 9 Other Return status

Return status	Description
TTM:CONNECT	Establish connection successfully.
TTM:DISCONNECT	The remote device terminated the connection.
TTM:DISCONNECT FOR TIMEOUT	Link supervision timeout has expired.
TTM:SYSTEM-RST	The module will output the information after system reset.
TTM:REV-CMT4531B-V <sub>x.x</sub>	Firmware version, the module will output the information after system reset, and the information may change with the firmware update.

## 10 Contact Information

Shenzhen Hope Microelectronics Co., Ltd.

Address: 30th floor of 8th Building, C Zone, Vanke Cloud City, Xili Sub-district,  
Nanshan, Shenzhen, GD, P.R. China

Tel: +86-755-82973805

Post Code: 518055

Email: [sales@hoperf.com](mailto:sales@hoperf.com)

Website: [www.hoperf.com](http://www.hoperf.com)