

FEATURES

- Supply voltages from 3.0V to 5.5V
- Dual-channel
- 120kbps data rates
- 15kV HBM ESD-Protected
- 8kV IEC-4100-4-2 Contact Discharge

PRODUCT APPEARANCE

Provide green and environmentally friendly lead-free package

DESCRIPTION

SIT3232E is a 3.0V to 5.5V power-supply, dual-channel, high ESD-protected, low-power RS-232 transceiver that fully meets the requirements of the TIA/EIA-232 standard.

SIT3232E includes two drives and two receivers, with enhanced ESD protection function, reaching the protection capacity of HBM ESD above 15kV and 8kV IEC-4100-4-2 contact discharge.

When powered, the charge pump only needs four 0.1 μ F external capacitors to achieve a rate of 96kbps error-free data transmission. Each driver and receiver can be used independently.

PIN CONFIGURATION

Fig 1 pin configuration

PIN DESCRIPTION

PIN	SYMBOL	DESCRIPTION
1	C1+	Positive Terminal for the first Charge Pump Capacitor
2	V+	Doubled Voltage Terminal
3	C1-	Negative Terminal for the first Charge Pump Capacitor
4	C2+	Positive Terminal for the second Charge Pump Capacitor
5	C2-	Negative Terminal for the second Charge Pump Capacitor
6	V-	Inverted Voltage Terminal
7	T2OUT	Second Transmitter Output Voltage
8	R2IN	Second Receiver Input Voltage
9	R2OUT	Second Receiver Output Voltage
10	T2IN	Second Transmitter Input Voltage
11	T1IN	First Transmitter Input Voltage
12	R1OUT	First Receiver Output Voltage
13	R1IN	First Receiver Input Voltage
14	T1OUT	First Transmitter Output Voltage
15	GND	Ground
16	VCC	Supply Voltage

LIMITING VALUES

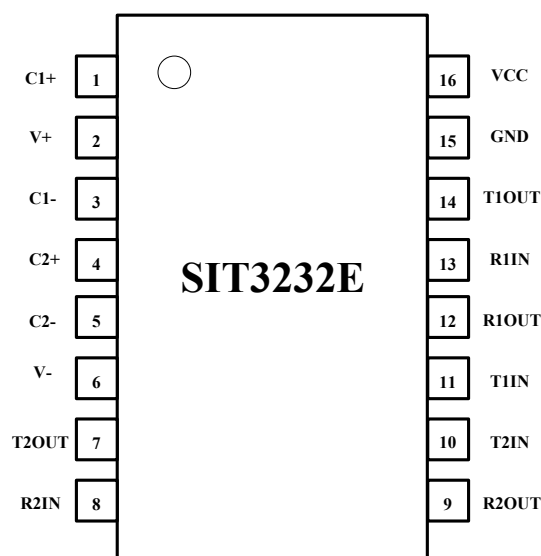
PARAMETER	SYMBOL	VALUE	UNIT
Supply voltage	VCC	-0.3~+6	V
Doubled Voltage Terminal	V+	VCC-0.3~+7	V
Inverted Voltage Terminal	V-	+0.3~-7	V
$V+ + V- $		+13	V
Transmitter Input Voltage Range	T1IN, T2IN	-0.3~+6	V
Receiver Input Voltage Range	R1IN, R2IN	±25	V
Transmitter Output Voltage Range	T1OUT, T2OUT	±13.2	V

PARAMETER	SYMBOL	VALUE	UNIT
Receiver Output Voltage Range	R1OUT, R2OUT	-0.3~VCC+0.3	V
Operating Temperature	T _A	-40~85	°C
Storage Temperature	T _{stg}	-60~150	°C
Soldering Temperature		300	°C
Continuous Power	SOP16	760	mW
	DIP16	840	mW

The maximum limit parameters mean that exceeding these values may cause irreversible damage to the device. Under these conditions, it is not conducive to the normal operation of the device. The continuous operation of the device at the maximum allowable rating may affect the reliability of the device. The reference point for all voltages is ground.

SUPPLY CURRENT

PARAMETER	SYMBOL	CONDITION	MIN.	TYP.	MAX.	UNIT
Supply Current with no load	I_{sup}			2		mA

(If there is no additional explanation, typical value is tested when $V_{CC}=+3.3V$, $Temp=25^{\circ}C$, $C1-C4=1\mu F$).

LOGIC INPUT ELECTRICAL CHARACTERISTICS

PARAMETER	SYMBOL	CONDITION	MIN.	TYP.	MAX.	UNIT
Logic Control Low Level	V_{TIN_L}	T1IN, T2IN			0.8	V
Logic Control High Level	V_{TIN_H}	T1IN, T2IN	2			V
Logic Control Hysteresis		T1IN, T2IN		0.3		V
Input Logic Current	I_{TIN}	T1IN, T2IN			± 1	μA

(If there is no additional explanation, typical value is tested when $V_{CC}=+3.3V$, $Temp=25^{\circ}C$, $C1-C4=1\mu F$).

RECEIVER OUTPUT ELECTRICAL CHARACTERISTICS

PARAMETER	SYMBOL	CONDITION	MIN.	TYP.	MAX.	UNIT
Receiver Output Logic-Low Voltage	V_{ROL}	$I_{OUT}=1.6mA$, $V_{CC}=5V$ or $3.3V$			0.4	V
Receiver Output Logic-High Voltage	V_{ROH}	$I_{OUT}=-0.5mA$, $V_{CC}=5V$ or $3.3V$	$V_{CC}-0.6$	$V_{CC}-0.1$		V

(If there is no additional explanation, typical value is tested when $V_{CC}=+3.3V$, $Temp=25^{\circ}C$, $C1-C4=1\mu F$).

RECEIVER INPUT ELECTRICAL CHARACTERISTICS

PARAMETER	SYMBOL	CONDITION	MIN.	TYP.	MAX.	UNIT
Receiver Input Range	V_{RIN}		-25		+25	V
Receiver Input Low Threshold	V_{RIL}	$V_{CC}=3.3V$	0.6	1.1		V
		$V_{CC}=5V$	0.8	1.5		V
Receiver Input High Threshold	V_{RIH}	$V_{CC}=3.3V$		1.5	2.4	V
		$V_{CC}=5V$		1.9	2.4	V

PARAMETER	SYMBOL	CONDITION	MIN.	TYP.	MAX.	UNIT
Receiver Input Hysteresis				0.4		V
Receiver Input Impedance	R_{RIN}		3	5	7	k Ω

(If there is no additional explanation, typical value is tested when $V_{CC}=+3.3V$, Temp=25°C, C1-C4=1 μ F).

TRANSMITTER OUTPUT ELECTRICAL CHARACTERISTICS

PARAMETER	SYMBOL	CONDITION	MIN.	TYP.	MAX.	UNIT
Transmitter Output Swing	V_{TOUT}	All output ports of transmitter connect 3k Ω load to ground	± 4	± 5		V
Transmitter Output Impedance	R_{TOUT}	$V_{CC}=0V$, Transmitter Input= $\pm 2V$	300			Ω
Transmitter Short-Circuit Current	I_{sc}				60	mA

(If there is no additional explanation, typical value is tested when $V_{CC}=+3.3V$, Temp=25°C, C1-C4=1 μ F).

ESD PROTECTION

PARAMETER	SYMBOL	CONDITION	MIN.	TYP.	MAX.	UNIT
R1IN、R2IN T1OUT、T2OUT		HBM		± 15		kV
		Air Discharge		± 15		kV
		Contact Discharge		± 8		kV

SWITCHING CHARACTERISTICS PARAMETER

PARAMETER	SYMBOL	CONDITION	MIN.	TYP.	MAX.	UNIT
Rate	Speed	$R_L=3k\Omega$, $C_L=1000pF$		96		kbps
Receiver Propagation delay	t_{RPHL}	$C_L=150pF$		300		ns
	t_{RPLH}			300		ns
	$ t_{RPHL}-t_{RPLH} $			150		ns
	$ t_{TPHL}-t_{TPLH} $			150		ns

PARAMETER	SYMBOL	CONDITION	MIN.	TYP.	MAX.	UNIT
Transmitter Slew Rate	SR	RL=3kΩ~7kΩ, CL=150pF~1000pF from-3.0V~3.0V or from3.0V~-3.0V See Fig 2 and Fig 3	4		30	V/μs

(If there is no additional explanation, typical value is tested when VCC=+3.3V, Temp=25°C, C1-C4=1μF).

TEST CIRCUIT

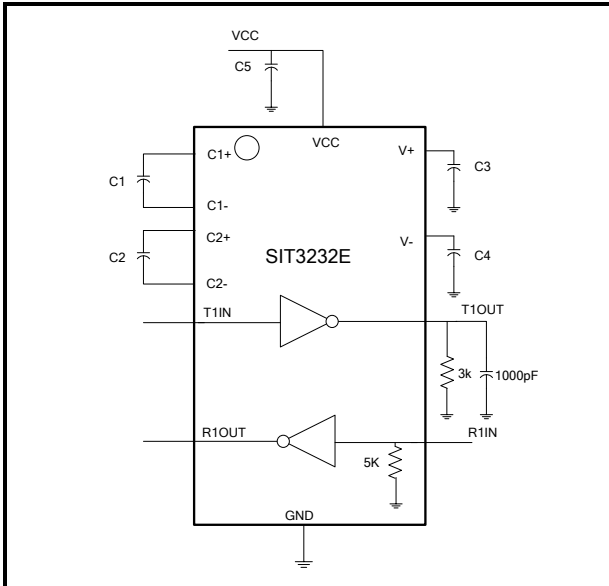

Fig 2 minimum swing rate test circuit

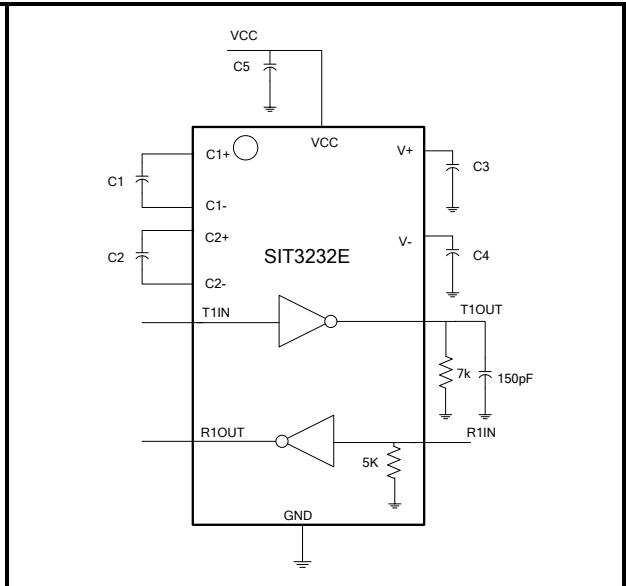

Fig 3 maximum swing rate test circuit

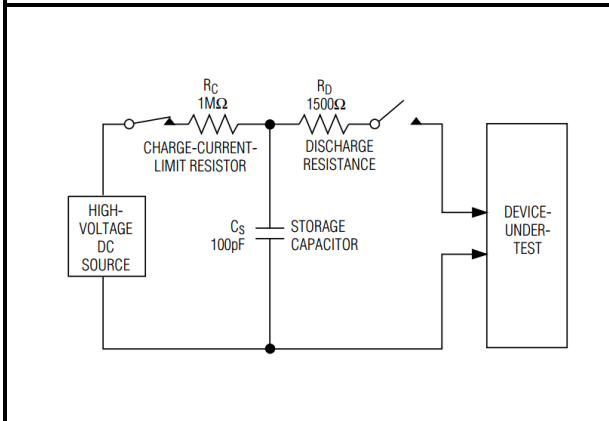

Fig 4 ESD test model of human body mode

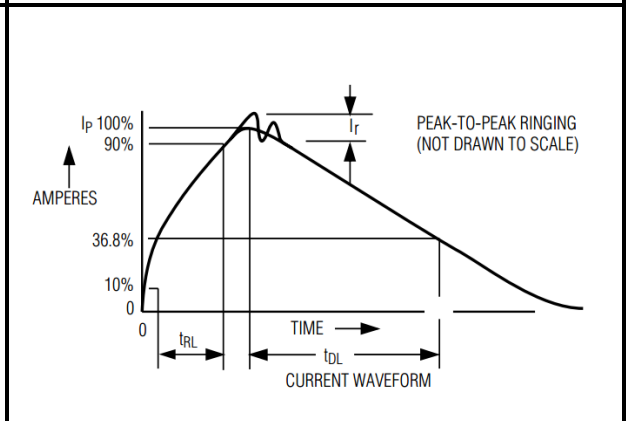

Fig 5 human body mode current waveform

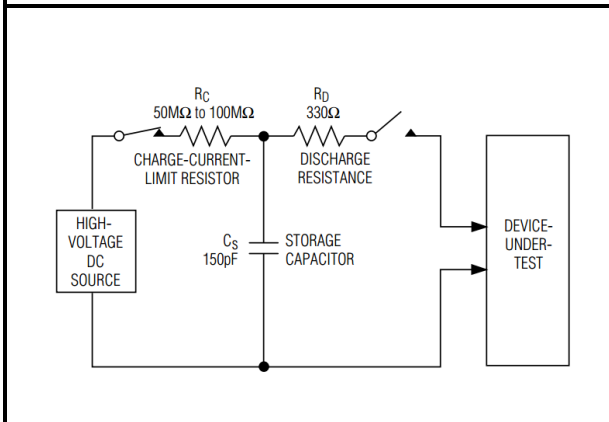

Fig 6 ESD test model of IEC 1000-4-2

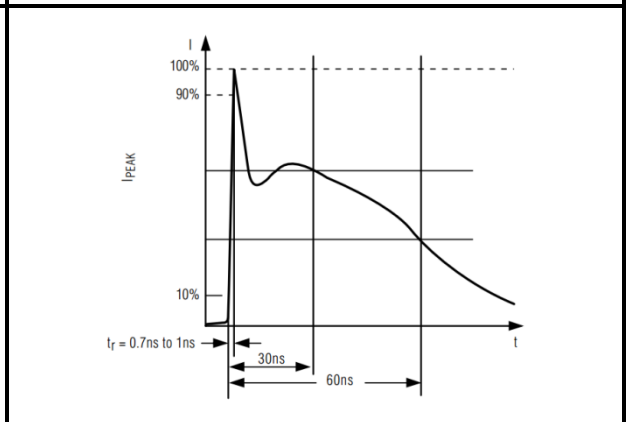

Fig 7 current waveform of IEC 1000-4-2 ESD

ADDITIONAL DESCRIPTION

1 Dual Charge-Pump Operation

SIT3232E has a two-way charge pump inside to support the chip's voltage conversion work. Dual-electric pump provides +5.5V and -5.5V output voltage in the range of 3.0 ~ 5.5V, each charge pump requires a capacitor (C1, C2) and an energy storage capacitor (C3, C4) to generate V+ and V-power supplies, as shown in [Fig 8](#).

2 RS232 Transmitter

Convert the TTL/CMOS logic voltage to a voltage compatible with the EIA/TIA-232 standard. SIT3232E Transmitter can guarantee 120kbps data rate under the worst operating conditions (Parallel load of 3kΩ resistor and 1000pf capacitor). Transmitter can drive multiple receivers in parallel. There is no pull-up resistance inside the input terminals T1IN and T2IN of SIT3232E transmitter. If the transmitter is not used, the unused input terminals T1IN and T2IN can be connected to GND or VCC.

3 RS232 Receiver

The SIT3232E has two separate receivers that convert the RS-232 signal to the CMOS logic output level.

4 ESD Protection

All pins of SIT3232E adopt ESD protection structure, and all driver outputs and receiver inputs have additional electrostatic protection capability. It can withstand ±15kV ESD (HBM) discharge, contact discharge above ±8KV and air gap discharge above ±15kV. The ESD protection structure can withstand the impact of high voltage ESD under all conditions, including standard working mode and power-off mode.

5 Typical Application

Typical dual-Path application scenarios are shown in [Fig 8](#), where the C1-C5 typical capacitance value is 0.1μF.

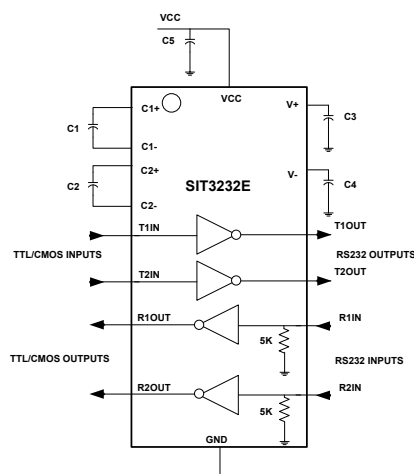
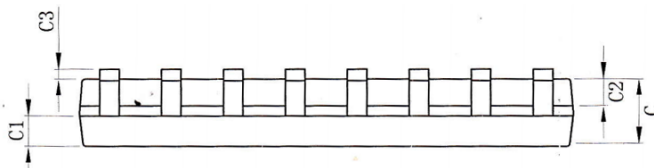
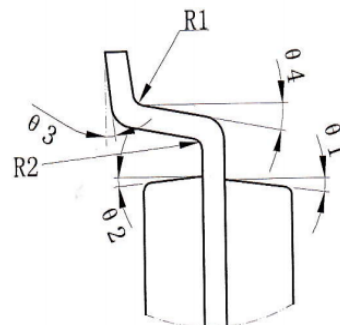
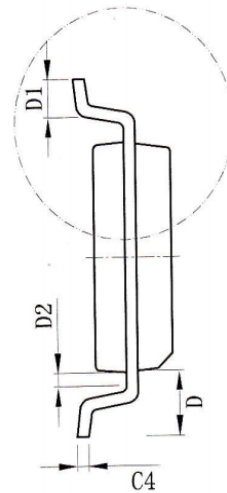
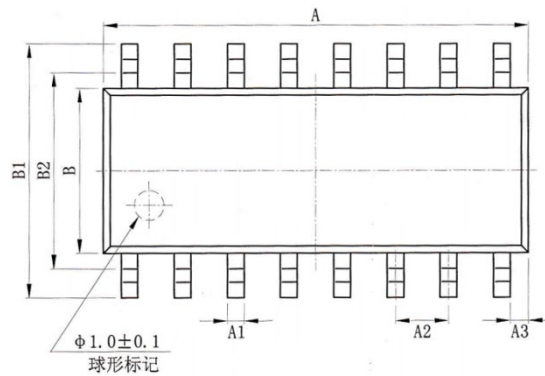

Fig 8 Typical dual-Path application scenarios

SOP16 DIMENSIONS
PACKAGE SIZE

SIZE SYMBOL	MIN./mm	MAX./mm
A	9.80	10.00
A1	0.356	0.456
A2	1.27TYP	
A3	0.302TYP	
B	3.85	3.95
B1	5.84	6.24
B2	5.00 TYP	
C	1.40	1.60
C1	0.61	0.71
C2	0.54	0.64
C3	0.05	0.25
C4	0.203	0.233
D	1.05 TYP	
D1	0.40	0.70
D2	0.15	0.25
R1	0.20TYP	
R2	0.20TYP	
θ1	8°~12°TYP4	
θ2	8°~12°TYP4	
θ3	0°~8°	
θ4	4°~12°	



SSOP16(0.65) DIMENSIONS
PACKAGE SIZE

SIZE SYMBOL	MIN/mm	MAX/mm
A	6.15	6.25
A1	0.30TYP	
A2	0.65TYP	
A3	0.675TYP	
B	5.25	5.35
B1	7.65	7.95
B2	0.60	0.80
C	1.70	1.80
C1	1.75	1.95
C2	0.799	
C3	0.152	
C4	0.172	
H	0.05	0.15
θ	12°TYP4	
$\theta 1$	12°TYP4	
$\theta 2$	10°TYP	
$\theta 3$	0°~8°	
R	0.20°TYP	
R	0.15°TYP	

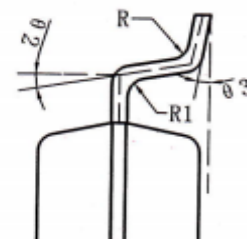
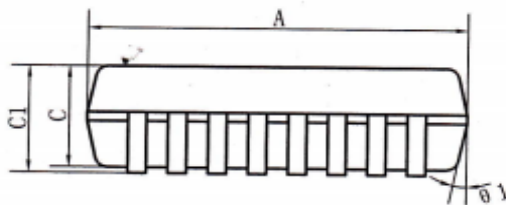
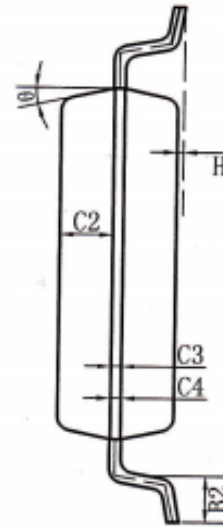
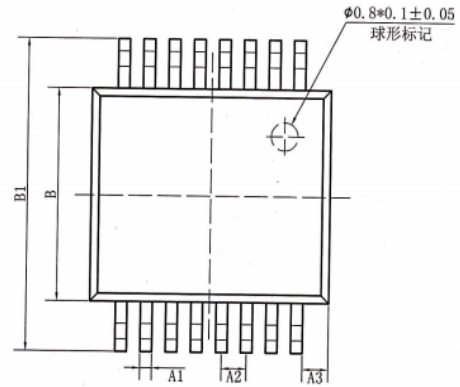

TSSOP16 DIMENSIONS
PACKAGE SIZE

SIZE SYMBOL	MIN./mm	TYP./mm	MAX./mm
A	--	--	1.20
A1	0.05		0.15
A2	0.90	1.00	1.05
b	0.20	--	0.30
b1	0.19	0.22	0.25
c	0.110	0.127	0.145
c1	0.12	0.13	0.14
D	4.86	4.96	5.06
E	6.20	6.40	6.60
E1	4.30	4.40	4.50
e	0.65BSC		
L	0.45	0.60	0.75
L1	1.00BSC		
	0°	--	8°

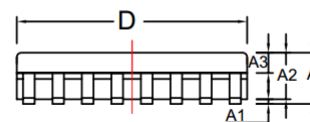
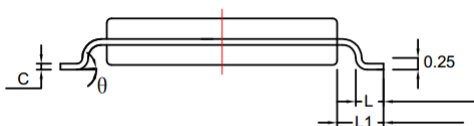
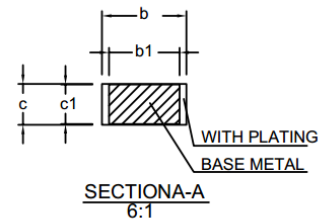
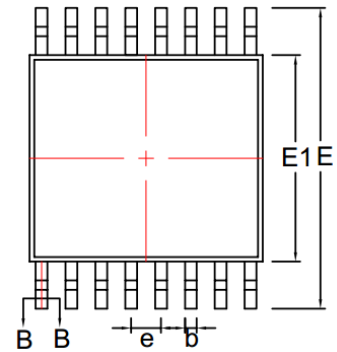

WSOP16 DIMENSIONS
封装尺寸

标注	尺寸	最小值/mm	最大值/mm
A		-	2.65
A1		0.10	0.30
A2		2.25	2.35
A3		0.97	1.07
D		10.10	10.50
E		10.26	10.60
E1		7.30	7.70
e	1.27BSC		
L		0.55	0.85
L1	1.4BSC		
H		0.345	0.365
R	0.20TYP		
R1	0.30TYP		
θ		0°	8°
θ_1	45°TYP		
θ_2	12°TYP		
θ_3		0°	8°
θ_4		0°	10°

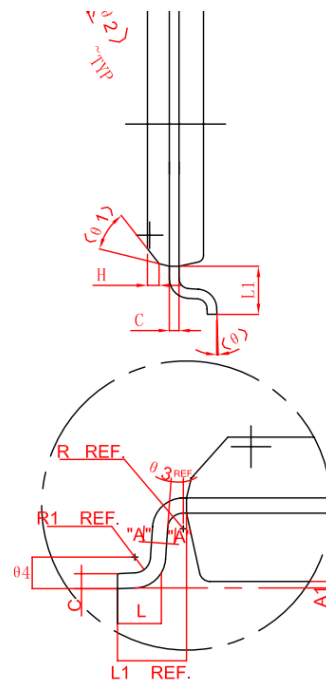
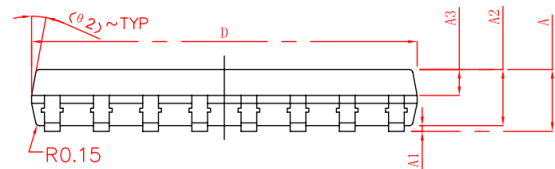
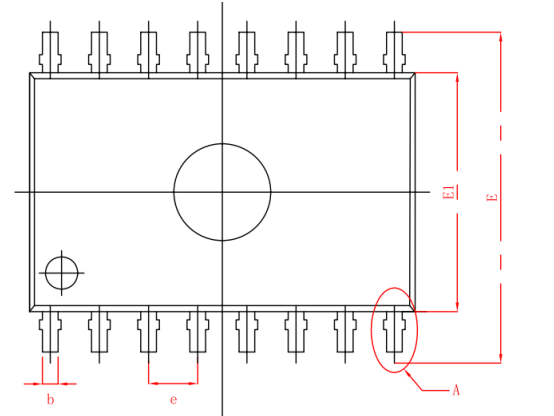

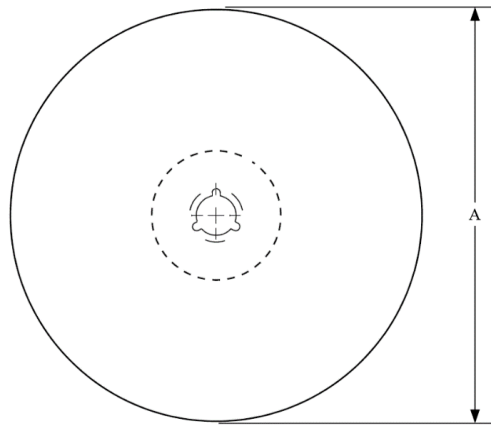
TAPE AND REEL INFORMATION

A0	Dimension designed to accommodate the component width
B0	Dimension designed to accommodate the component length
K0	Dimension designed to accommodate the component thickness
W	Overall width of the carrier tape
P1	Pitch between successive cavity centers

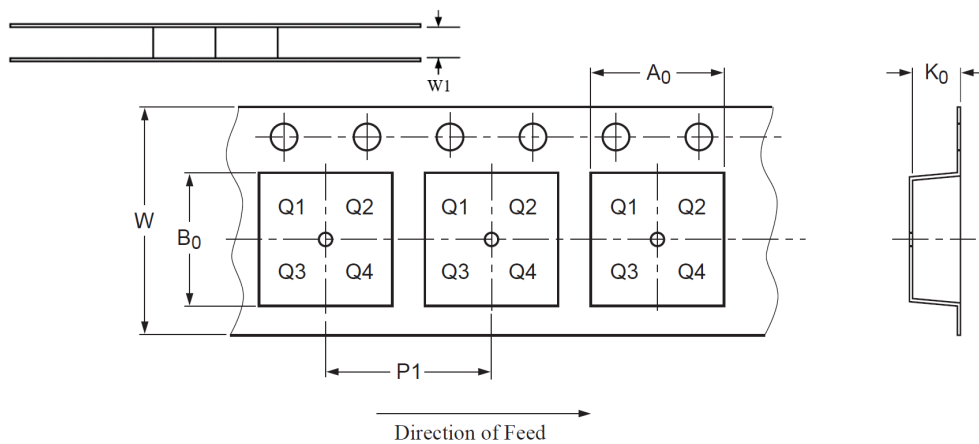

Direction of Feed →

PIN1 is in quadrant 1

Package Type	Reel Diameter A (mm)	Tape width W1 (mm)	A0 (mm)	B0 (mm)	K0 (mm)	P1 (mm)	W (mm)
SOP16	330	16	6.43±0.10	10.40±0.1	1.85±0.10	8.00±0.1	16.00 ^{+0.30} _{-0.10}
SSOP16	330	16	8.30 ^{+0.10} _{-0.10}	6.60 ^{+0.10} _{-0.10}	2.40 ^{+0.10} _{-0.10}	8.00±0.1	16.00 ^{+0.30} _{-0.30}
TSSOP16	330	12	6.80±0.1	5.50±0.1	1.30±0.1	8.00±0.1	12.00±0.30

ORDERING INFORMATION

TYPE NUMBER	PACKAGE	PACKING
SIT3232EESE	SOP16	Tape and reel
SIT3232EEAE	SSOP16	Tape and reel
SIT3232EEUE	TSSOP16	Tape and reel
SIT3232EEWE	WSOP16 Wide body	Tube

SOP 16, SSOP16 and TSSOP16 is packed with 2500 pieces/disc in braided packing. WSOP16 is packed with 44 pieces/tube in tubed packaging.

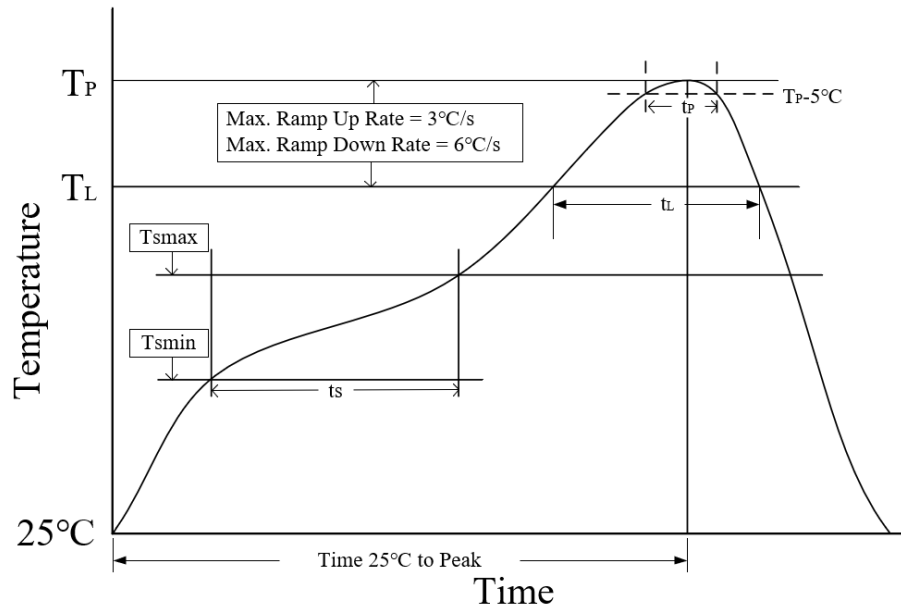
REFLOW SOLDERING

Parameter	Lead-free soldering conditions
Ave ramp up rate (T_L to T_P)	3 °C/second max
Preheat time t_s ($T_{smin}=150\text{ °C}$ to $T_{smax}=200\text{ °C}$)	60-120 seconds
Melting time t_L ($T_L=217\text{ °C}$)	60-150 seconds
Peak temp T_P	260-265 °C
5°C below peak temperature t_p	30 seconds
Ave cooling rate (T_P to T_L)	6 °C/second max
Normal temperature 25°C to peak temperature T_P time	8 minutes max

Important statement

SIT reserves the right to change the above-mentioned information without prior notice.

REVISION HISTORY

Version number	Data sheet status	Revision date
V1.0	Initial version.	September 2017
V1.1~V1.10	Adjusted format.	September 2017 to August 2019
V1.11	Updated the parameters of “transmitter output electrical characteristics”; Added the dimensions of SSOP16, TSSOP16 packages.	August 2019
V1.12	Added test conditions description of “supply current” typical value.	February 2020
V1.13	Adjusted format.	March 2020
V1.14	Added the dimensions of SOPW16 wide body package; Update ordering information.	August 2020
V1.15	Updates the receiver propagation delay parameter information.	January 2021
V1.16	Updated the communication rate; Updated the “Transmitter Output Swing” parameter; Added tape and reel information; Updated ordering information; Added reflow soldering information; Added revision history.	February 2023