



2023.5.3

Shenzhen Shen Maoxin Electronics Co., Ltd.

Marketing	Technical
Ms Diana Fang	Mr.Leo Huang

SPECIFICATION FOR ALUMINUM ELECTROLYTIC CAPACITOR

- 1. PRODUCT SCREW TERMINAL ALUMINUM ELECTROLYTIC CAPACITOR
- 2. Part Number ULXA2G472AE143MT4L 400V4700uF 77*143mm 85C 15000H With Bolt Type
- 3. CUSTOMER **JSC MT-Systems**

APPROVAL OF SPECIFICATION



1. Scope

This specification sheet describes the regulations for ST/SI type aluminum electrolytic capacitor

2. Relative Standard

JISC5101-1-1998 · C5101-4-1998 · C0051-1994 · C0040-1995 · C0050-1996

3. Product Code Formation

Please see the data book.

4. Performance

Unless otherwise specified, the measurement should be conducted under the following conditions. Temperature: 15 ~ 35 °C , relative humidity: 45 ~ 75% and atmospheric pressure: 86 ~ 107Pa.



If the test result are undeterminable, it should be measured at the temperature: $20 \pm 2^{\circ}\text{C}$, relative humidity: 60~70% and atmospheric pressure: 86~107Pa.

No.	Item	Condition	Specification	Relative Standard
4.1	Category Temperature Range	The ambient temperature range at which the capacitor can be used continuously.	$-40 \sim +85^{\circ}\text{C}$	
4.2	Rated Voltage		DC400V	
4.3	Capacitance	Frequency: $120 \pm 12\text{Hz}$ Measuring Voltage: Not more than $0.5V_{\text{rms}}$	$4700 \mu\text{F}$ ($\pm 20\%$)	JISC5101-4
4.4	Dissipation Factor $\tan \delta$	Same as the capacitance	Not more than 0.20	JISC5101-4
4.5	Leakage Current	The capacitor should be connected to $1000 \pm 100 \Omega$ resistor in series, then apply rated voltage. After 5 minutes, current value should be measured.	Not more than $5000 \mu\text{A}$	JISC5101-4
4.6	Rated Ripple Current	Temperature: $85 \pm 2^{\circ}\text{C}$ Ripple current: The root-mean-square value of 120Hz sine alternating current.	14.5Arms	
4.7	Surge Voltage	Applied Voltage: 450VDC Temperature: $15 \sim 35^{\circ}\text{C}$ Period: Within 6 ± 0.5 minutes, 30 ± 5 seconds charged. The charge resistance should be 1000Ω , and then self-discharged. Round: 1000times After the temperature returned to 20°C , the capacitor must meet the specification listed right.	Capacitance Change: Not more than $\pm 20\%$ of initial value Dissipation Factor: Not more than 200% of specified value Leakage Current: Not more than the specified value	
4.8	Endurance	Temperature: $85 \pm 2^{\circ}\text{C}$ Voltage: Rated Voltage 400V But, direct-current voltage + ripple peak value should not exceed rated voltage. Time: 15,000hours After the temperature returns to 20°C , the capacitor meet the specification listed right.	Capacitance Change: Not more than $\pm 20\%$ of initial value Dissipation Factor: Not more than 200% of specified value Leakage Current: Not more than the specified value Appearance: Should not significantly be changed	
4.9	High-temperature Shelf Storage	Temperature: $85 \pm 2^{\circ}\text{C}$ Time: 1000hours After the temperature returns to 20°C , the capacitor meet the specification listed right.	Capacitance Change: Not more than $\pm 20\%$ of initial value Dissipation Factor: Not more than 175% of specified value Leakage Current: Not more than the specified value	
4.10	Terminal Strength	Tensile Strength: Apply 20N of static load for 10 seconds towards outward direction of terminals.	When measuring capacitance, there should be no poor contact, wire breakage, nor short-circuit.	
4.11	Endurance against Vibration	Vibration Frequency Range: $10 \sim 55\text{Hz}$ Total Amplitude: 1.5mm Rate of Scanning: $10 \sim 55 \sim 10\text{Hz}$ about 1minute Vibration direction and time: X-Y-Z 2hours for each direction, total 6hours	Capacitance Change: Not more than $\pm 5\%$ of initial value Appearance: Should not significantly be changed	JISC5101-1 and JISC0040
4.12	Pressure Relief Vent Performance	Apply 10A DC reverse current	Pressure relief vent should properly function and metal pieces should not be dispersed. Or after testing 30 minutes, there are no irregularities	JISC5101-1 and JISC5101-4

5. Multiplier for Ripple Current

Frequency(Hz)	50/60	120	300	1k	≥10k
Coefficient	0.8	1.0	1.1	1.3	1.4

Temperature(°C)	40	60	70	85
Coefficient	2.3	1.7	1.4	1.0

6. Dimensions & Accessories for bolt mounting

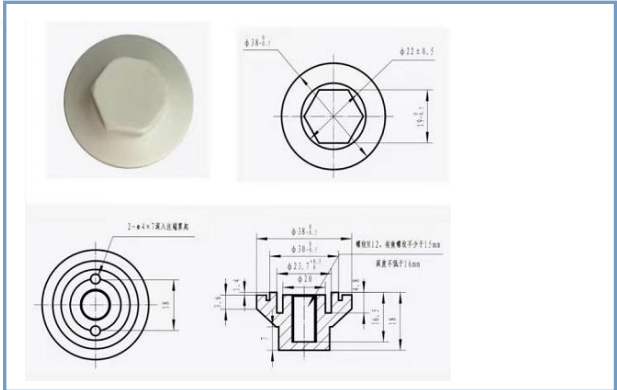
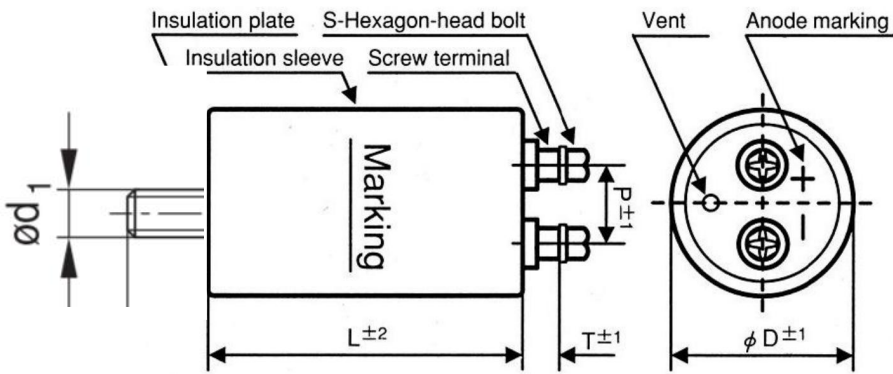

E-cap type	Diameter (D)	Distance of terminal(P)	Terminal	Length (L)	Bolt Type
Screw Terminal	77mm	32.0mm	M6*17mm	143mm	M12*16mm

No.	Components	Material
1	Can	Aluminum
2	Sleeve	PVC
3	Cover disc	PPS/Phenol
4	Tab	Aluminum
5	Winding	Foil,Paper and electrolyte

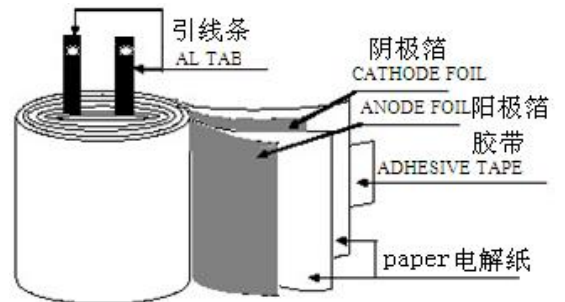

7. Others

- ①This product is in full compliance with RoHS Directive.
- ②This product is not to be rinsed with any liquid, especially organic solvents.

Caution for Proper Use of Aluminum Electrolytic Capacitors

When using aluminum electrolytic capacitors, please pay attention to the points listed below.

If the following types of electrical loads are applied to aluminum electrolytic capacitors, rapid deterioration of electrical property occurs:

- ◆ Reverse Voltage
- ◆ Over voltage (exceeding rated working voltage)
- ◆ Exceeding Rated Ripple Current
- ◆ Severe Charging/Discharging

At such times can cause severe heating and gas emission, which result in electrolyte leakage from the sealed area.

Subsequently, pressure relief vent operated due to internal pressure. In the worst case, or ignition may occur, which can result in capacitor combustion.

1. Caution during Circuit Design

1) Operational Environment, Mounting Environment and Conditions

◆ Ensure that operational and mounting conditions accord with the specified conditions detailed in the catalog or specification sheets.

2) Operating Temperature, Ripple Current and Load Life

◆ Operating temperature and applied ripple current should be within the specified value in the catalog or specification sheets.

① Do not use aluminum electrolytic capacitors at temperature which exceeds the specified category temperature range.

② Do not apply excessive current to the capacitors, which exceeds the specified rated ripple current.

◆ During circuit design, please ensure that capacitors are selected to match with the lifetime requirements of the application.

3) Application

◆ Aluminum electrolytic capacitors are normally polarized. Reverse voltage or AC voltage should not be applied.

When polarity may flip over, bi-polar type should be used. but the bi-polar type cannot be used for AC.

◆ Standard aluminum electrolytic capacitors are not suitable for rapid charge and discharge applications.

Please consult with U-CON Electronics regarding special designed capacitors for rapid charge and discharge application.

4) Applied Voltage

◆ Do not exceed the rated voltage of capacitors.

5) Insulation

◆ Aluminum electrolytic capacitors should be electrically isolated from the following:

① Aluminum case, cathode lead wire, anode lead wire and circuit pattern.

② Auxiliary terminals of snap-in type, anode terminal, outward terminals and circuit pattern.

◆ The PVC sleeve of aluminum electrolytic capacitors is not guaranteed as an electrical insulator, therefore standard capacitor should not be used for applications where electrical insulation is required,

Please consult with U-CON Electronics regarding a higher grade of insulating sleeve.

6) Conditions of Use

◆ Aluminum electrolytic capacitors may fail if they are used under the following conditions:

① Exposure to water, high temperature and high humidity atmosphere, or condensation of moisture.

Exposure to salty water or oil, or an atmosphere that is filled with particles of salt or oil.

② In an atmosphere filled with toxic gases such as hydrogen sulfide, sulfurous acid, chlorine gas, ammonia, bromine, etc.

③ Exposure to direct sunlight, ozone, ultraviolet rays or radiation.

④ Under severe conditions where vibration and / or shock exceeding the condition specified in the catalog or specification sheets.

7) Considerations prior to Assembly

◆ In designing a circuit, the following matters should be ensured in advance to the capacitor's assembly on the printed circuit board (PC board) :

① Design the appropriate hole spacing to match the lead pitch of capacitors.

② Do not locate any wiring and circuit patterns directly above the capacitor's pressure relief vent.

③ Ensure enough free space above the capacitor's pressure relief vent. The recommended space is specified in the catalog or specification sheets.

④ In case the capacitor's pressure relief vent is facing the PC board, make a gas release hole on PC board.

⑤ The sealing side of the screw terminal type capacitor should not face down in the application. When the capacitors are mounted horizontally, the anode screw terminals must be positioned at upper side.

8) Consideration to Circuit Design

- ◆ Any copper lines or circuit patterns should not be laid under the capacitor.
- ◆ Parts which radiate heat should not be placed close to or reverse side of the aluminum electrolytic capacitors on the PC board.

9)Others

- ◆ Performance of electrical characteristics of aluminum electrolytic capacitors are affected by variation of operating temperature and frequency. Consider this variation when designing the circuit.
- ◆ Excessive holes and connection hole between both sides on the PC board should be avoided around or under the mounting area of the aluminum electrolytic capacitors on double sider or multi-layer PC board.
- ◆ Torque of tightening screw terminals should not exceed the specified value which is described in the catalog and specification sheets.
- ◆ Consider current balance when 2 or more aluminum electrolytic capacitors are connected in parallel.
- ◆ Use balancing resistors when 2 or more aluminum electrolytic capacitors are connected in series. In this case, the resistors should be connected parallel to the capacitors.

2. Caution for Assembling Capacitors

1) Caution before Assembly

- ◆ Aluminum electrolytic capacitors cannot be reused after mounting and applying electricity in unit.
The capacitors which are removed from PC board for the purpose of measuring electrical characteristics at the periodical inspection should only be reused for the same position.
- ◆ Aluminum electrolytic capacitors may accumulate charge naturally during storage. In this case, discharge through a $1K\ \Omega$ resistor before use.
- ◆ Leakage current of aluminum electrolytic capacitors may be increased during long storage time. In this case, the capacitors should be subject to voltage treatment using a $1k\ \Omega$ resistor before assembly.

2) In the Assembly Process-1

- ◆ Ensure rated voltage and capacitance of the capacitors before mounting.
- ◆ Ensure capacitors polarity before mounting.
- ◆ Do not use a capacitor which has been dropped onto a hard surface.
- ◆ Do not use a capacitor with damaged or dented cases or seals.

3) In the Assembly Process-2

- ◆ Capacitors should be mounted after ensuring that hole spacing on PC board matches the lead pitch of the capacitors.
- ◆ The snap-in type of capacitors should be mounted firmly on the PC board without a gap between the capacitor body and the surface of PC board.
- ◆ Avoid excessive force when clinching lead wire during auto-insertion process.
- ◆ Avoid excessive force to capacitors by automatic inserting machine, during mounting, parts inspection or centering operations.
- ◆ Utilize supporting material such as strap of adhesive to mount capacitors PC board when it is anticipated that vibration or shock will occur.

4) Hand Soldering

- ◆ Soldering conditions (temperature, time) should be within the specified conditions which are described in the catalog or specification sheets.
- ◆ In case lead wire reforming is necessary due to inappropriate pitch between capacitor and holes on PC board, stress to the capacitor should be avoided.
- ◆ In case it is required to remove the capacitors which were soldered onto the PC board for maintenance purpose, please melt the solder sufficiently in order to reduce stress on the lead wires/terminals of the capacitors.
- ◆ Soldering iron should never touch the capacitor's body.

5) Flow Soldering

- ◆ Do not dip capacitor's body into solder bath.
It should only be soldered on the reverse side of the PC board on which the capacitors are mounted.
- ◆ Soldering condition (preheat, soldering temperature, dipping time) should be within the specified range which is described in the catalog or specification sheets.
- ◆ Flux should not be adhered to capacitor's body but only to its terminals.
- ◆ Other devices which are mounted close to capacitors should not touch the capacitors.

6) Reflow Soldering

- ◆ Reflow soldering conditions (preheat, soldering, temperature, reflow time) should follow the specified range which is described in the catalog or specification sheets.
- ◆ Heating method should depend on surface of the capacitor color or materials when infrared rays are used because the capacitor's heat absorption on the surface color or materials. Check heat condition.
- ◆ Standard aluminum electrolytic capacitors cannot withstand two or more reflow processes.

7) Handling after Soldering

- ◆ Do not bent or twist the capacitor's body after soldering on PC board.
- ◆ Do not pickup or move PC board by holding the soldered capacitors.
- ◆ Do not hit the capacitors. Isolate capacitors from the PC board or other components when stacking PC boards to store.

8) PC Board Cleaning

- ◆ Standard aluminum electrolytic capacitors should be free from halogenated solvents during PC board cleaning after soldering.

9) Adhesives and Coating Materials

- ◆ Do not use halogenated adhesives and coating materials to fix the aluminum electrolytic capacitors.
- ◆ Flux between the surface of the PC board and sealing of capacitors should be cleaned before using adhesives or coating materials.
- ◆ Solvents should be dried up before using adhesives or coating materials.
- ◆ Do not cover up all the sealing area of capacitors with adhesives or coating materials, make only partial coverage.

3 . Caution during Use of Capacitors in Sets

- ◆ Do not touch the terminals of capacitors.
- ◆ Do not connect electrical terminals of the capacitor.
Keep the capacitors free from conductive solution, such as acid, alkali, etc.
- ◆ Ensure the operational environment of the equipment in which the capacitor has been built is within the specified condition mentioned in the catalog or specification sheets.

4 . Maintenance

- ◆ Periodical inspection should be carried out for the capacitors, which are used in industrial equipment.
Check the following points at the inspection.
 - ① Appearance: to ensure that pressure relief vent is open and to check if there is any indication or of electrolyte leakage.
 - ② Electrical characteristics: leakage current, capacitance, dissipation factor and the other points which are mentioned in the catalog or specification sheets.

5 . Emergency Action

- ◆ If the pressure relief vent is open and some gas blows out from the capacitor, turn the main switch of the equipment off or pull out the plug from the power outlet immediately.
- ◆ During pressure relief vent operation, extremely hot gas (over 100°C) may blow out from the vent area of the capacitors. Please keep your face and skin away from capacitors during its operation.
In case of eye contact, flush your eyes immediately with pure water. In case of ingestion, gargle with water immediately, and do not swallow. In case of skin contact, please wash skin immediately with soap and water.

6 . Storage Condition

- ◆ Aluminum electrolytic capacitors should not be stored in high temperature or in high humidity.
The suitable storage condition is 5°C-35°C, and less than 75% in relative humidity.
- ◆ Aluminum electrolytic capacitors should not be stored in damp or fumigated conditions caused by water, salty water or oil, atmosphere that is filled with particles of any liquid or oil.
- ◆ Do not store aluminum electrolytic capacitors in an environment full of hazardous gas (hydrogen sulfide, sulfurous acid, nitrous acid, chlorine gas, ammonia or bromine, etc.).
- ◆ Aluminum electrolytic capacitors should not be stored under exposure to ozone, ultraviolet rays or radiation.

7 . Disposal

- ◆ Please take either of the following actions in case of disposal.
 - ① Incineration (high temperature of more than 800°C) after crushing the capacitor's body.
 - ② Consignment to industrial waste agent.